

HAWKER HUNTER T.7/T.7A/T.53/T.70 RAF & EXPORT

CONVERSION SET



MARK I.

accessories

MKA14432
1/144 scale

Revell plastic parts (not included in this set)

parts not
to be used

MARK I Ltd.
PO Box 10
Prague 10 - Strašnice
CZ-100 31
Czech Republic
mark1@gmail.cz
www.4pluspublications.com

MARK I plastic parts

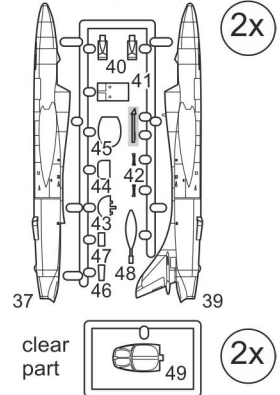
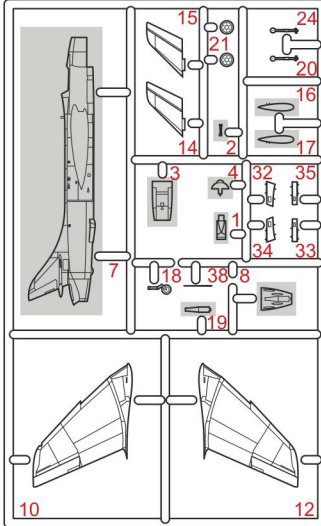
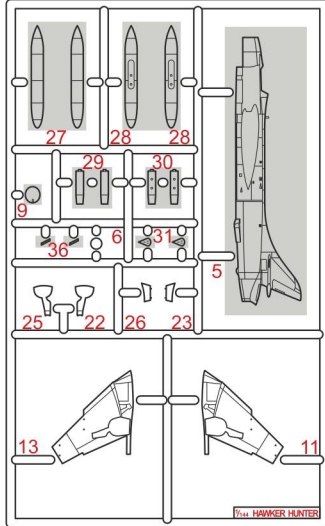

2x Repeat this operation

Glue

Don't glue

Decal

Detach/cut

? Optional

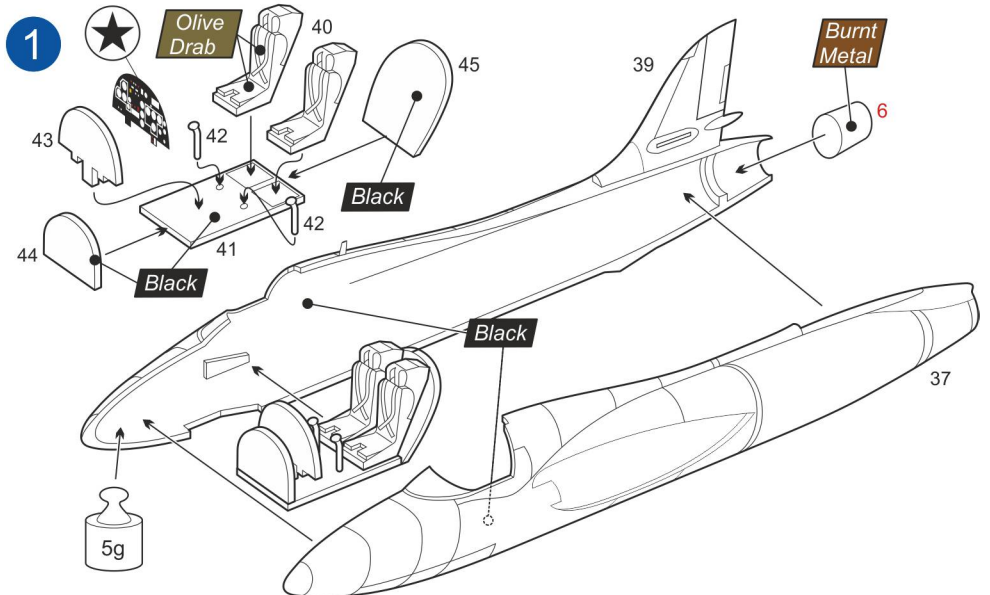

2

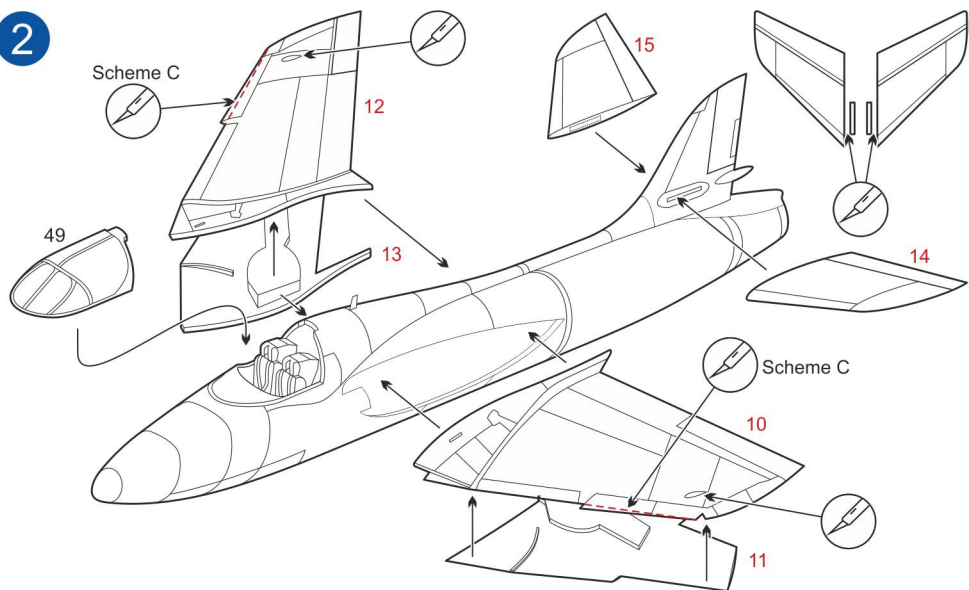

3

Main undercarriage & pylons position

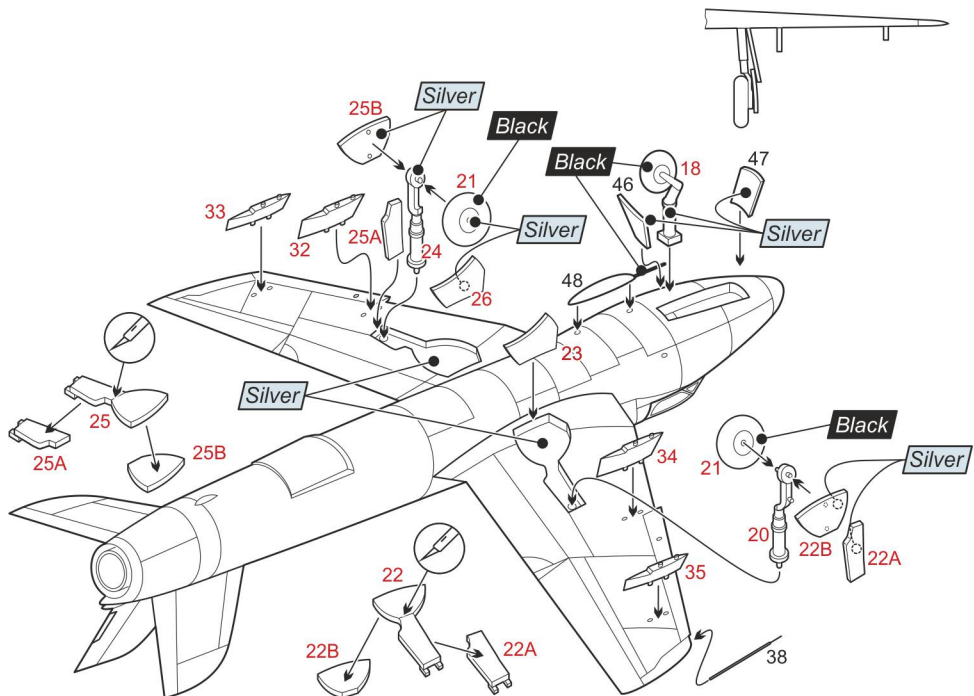

A Hawker Hunter T Mk.7A, XL568/ZF, No.12 Sq., RAF, Lossiemouth Air Base, Moray, Scotland, U.K., 1984-85

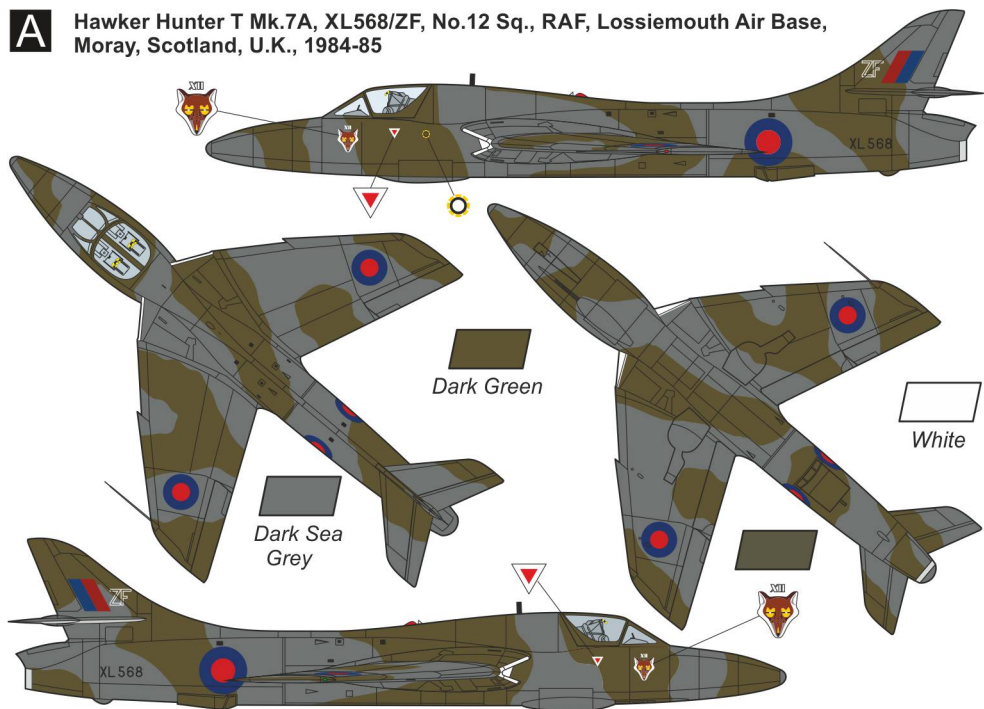

B Hawker Hunter T Mk.7, N-302, Royal Netherlands Air Force (Koninklijke Luchtmacht, KLu), Twente Air Base, the Netherlands, autumn 1958

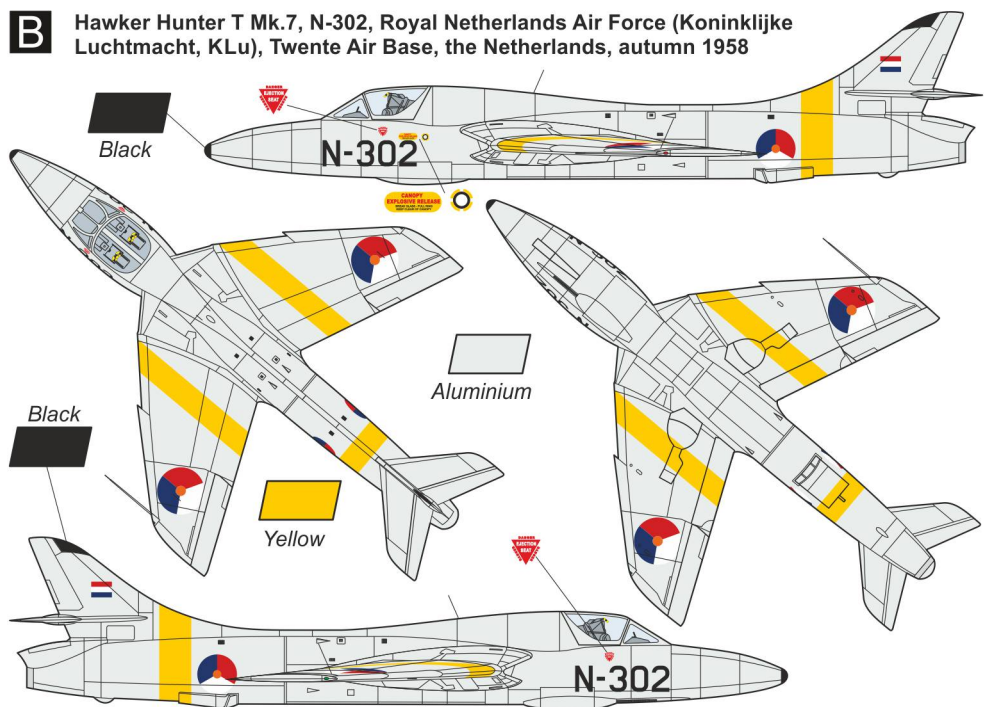

C Hawker Hunter T Mk.53, 53-271, White ET-271, No.724 Sq. (Esk 724), Royal Danish Air Force (Kongelige Danske Flyvevabnet), Skrydstrup Air Base, Denmark, 1970

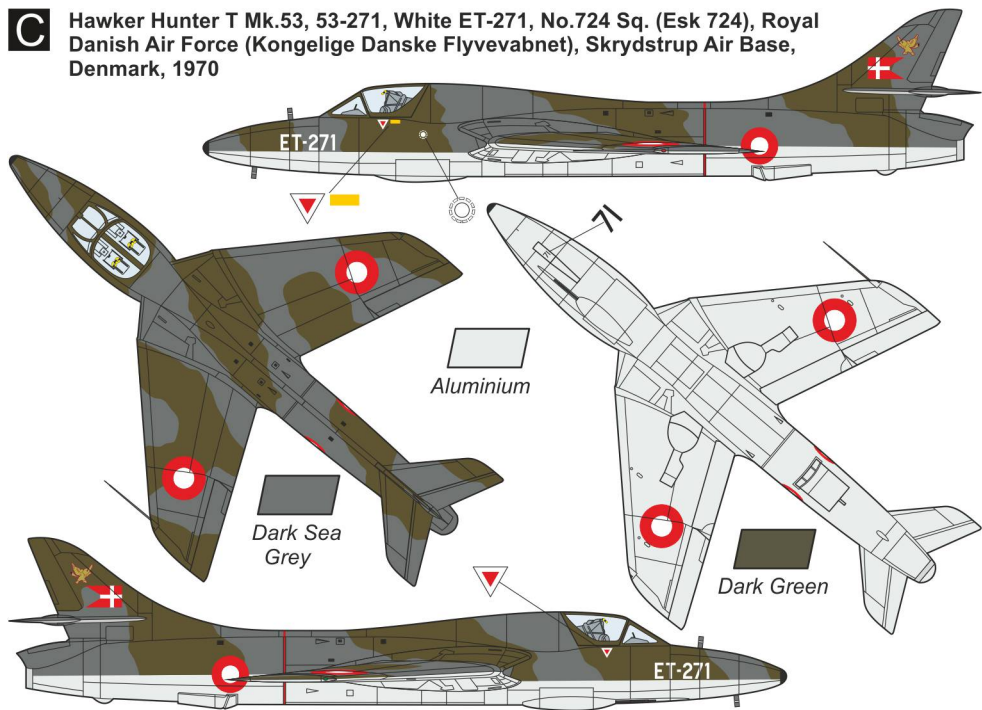

D Hawker Hunter T Mk.70, 70-617 (ex-XL605/G-9-214), No.6 Sq., Royal Saudi Air Force (Al-Quwwat al-Jawwiya al-Malakiya al-Sa'udiya), Taif Air Base, Saudi Arabia, late 1960s/early 1970s

