

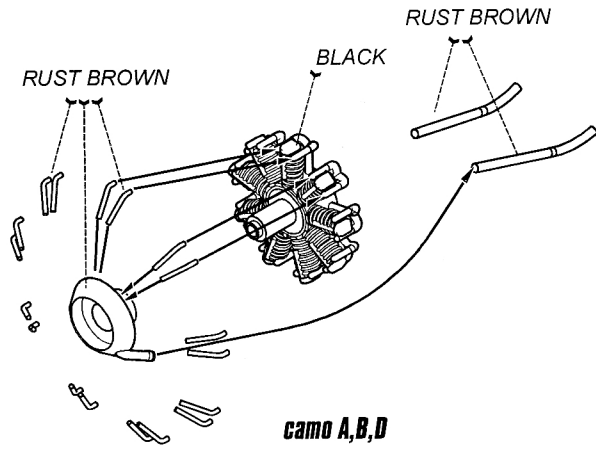

Westland Wapiti IIA

CMR 139
scale 1/72

CZECHMASTRA
R 2 5 1 8

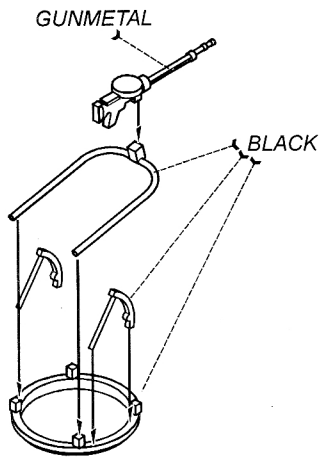
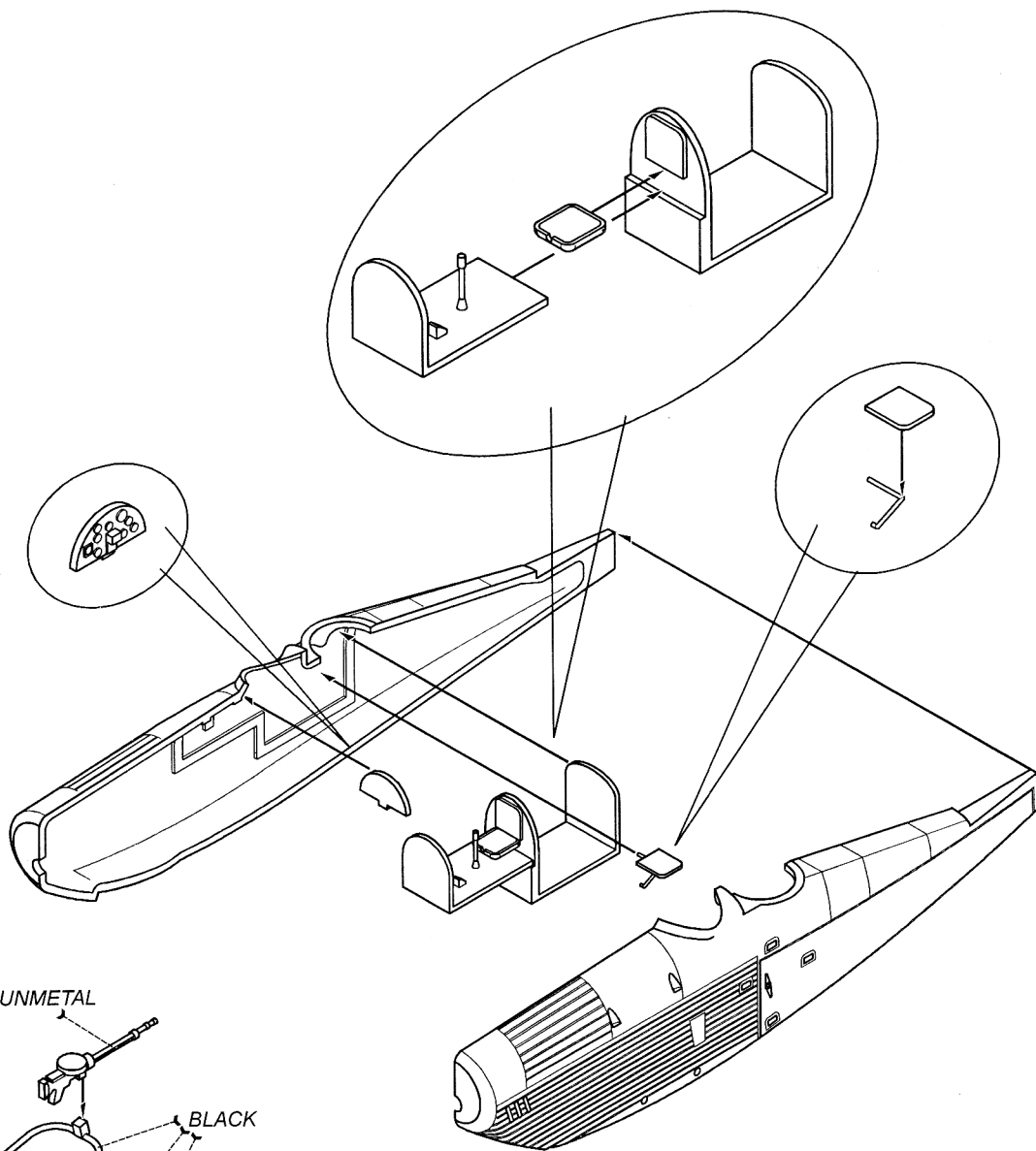

Bristol Jupiter W11F engine

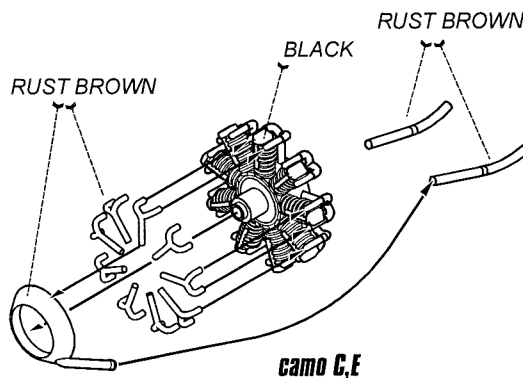



Westland Wapiti IIA

CMR 139
scale 1/72

CZECHMASTER
RESIN

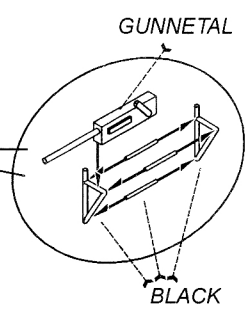
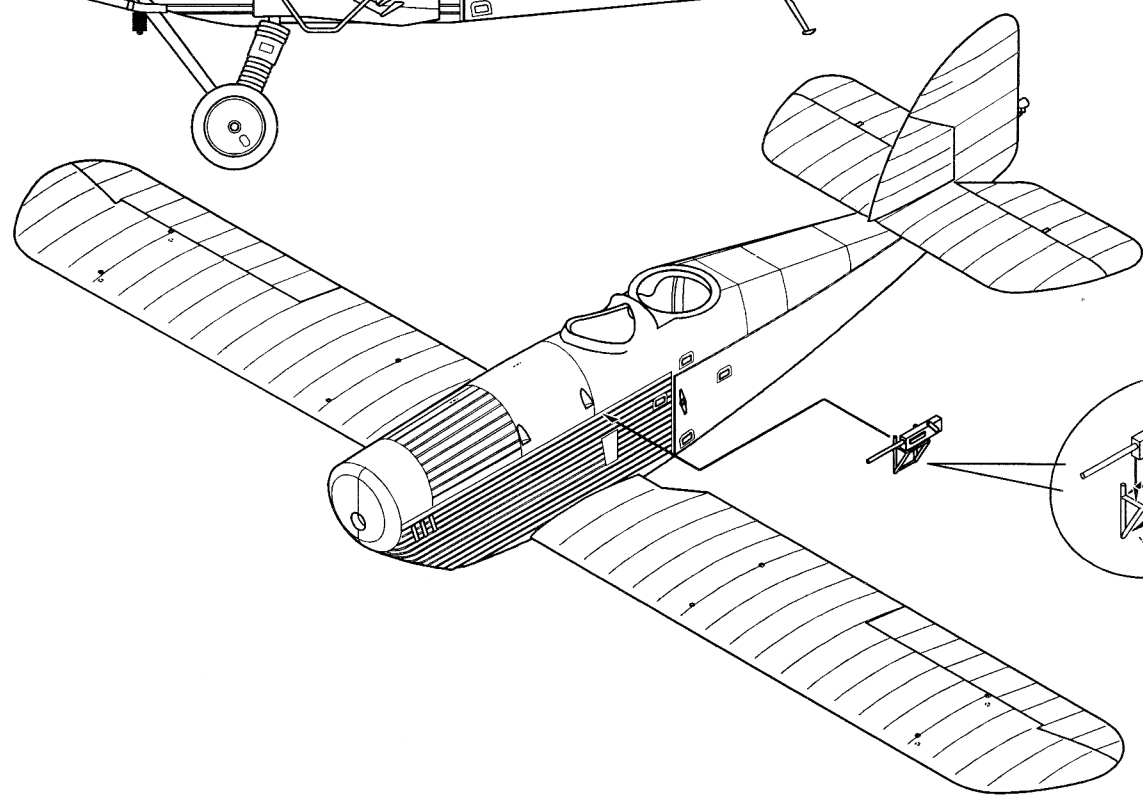
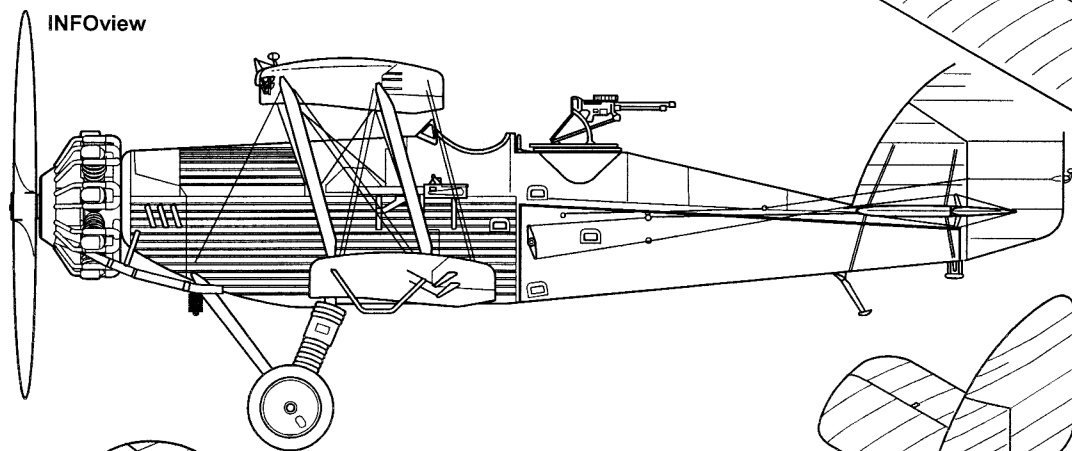
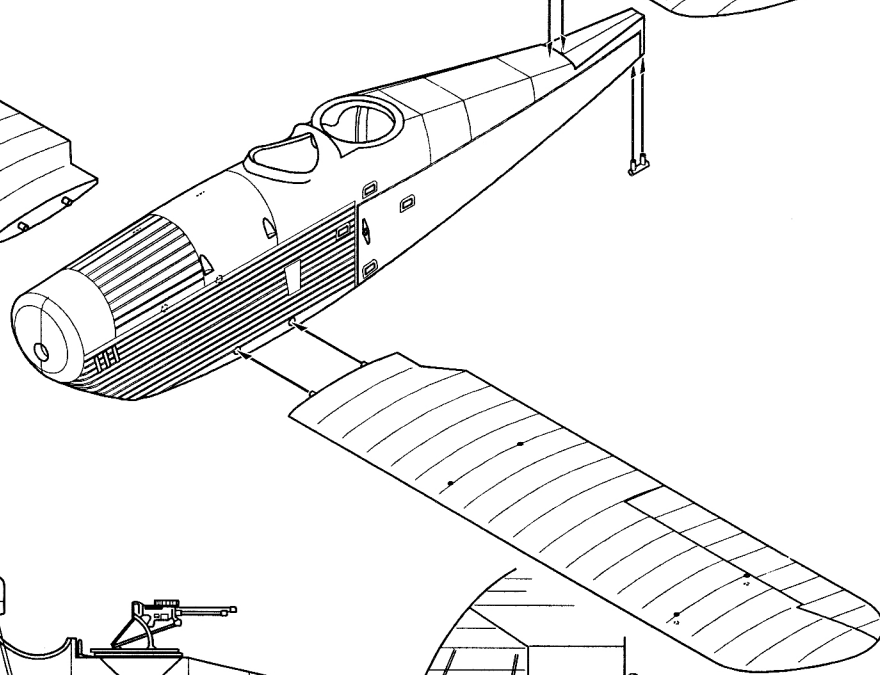
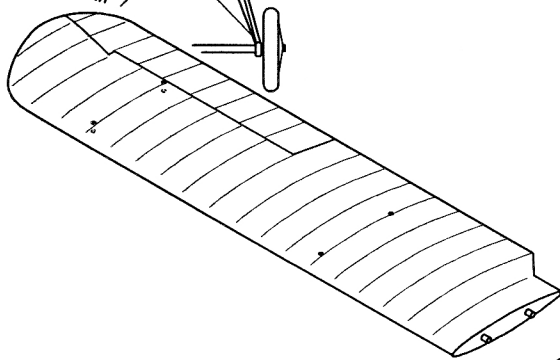
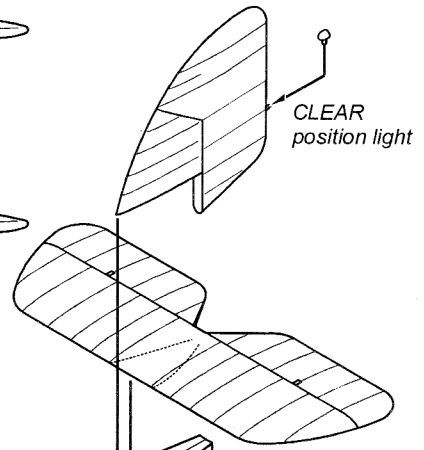
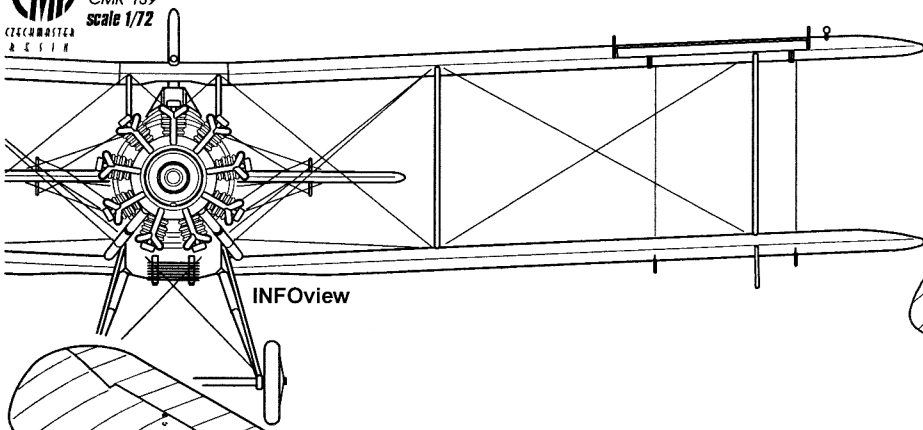

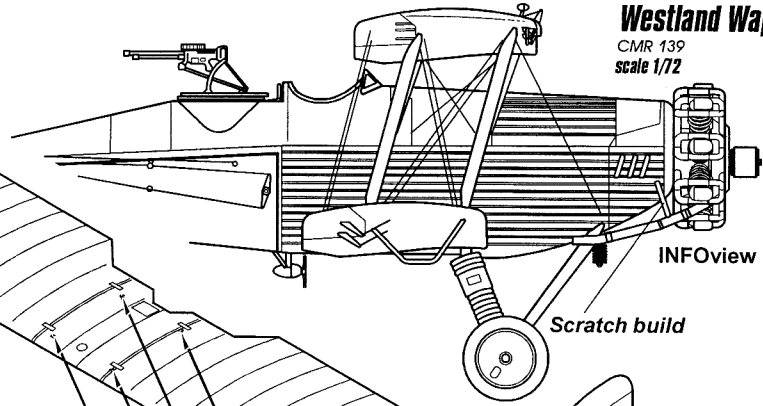

Scratch build RUST BROWN

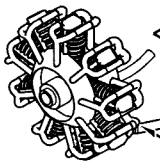

RUST BROWN

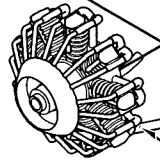

RUST BROWN

Scratch build

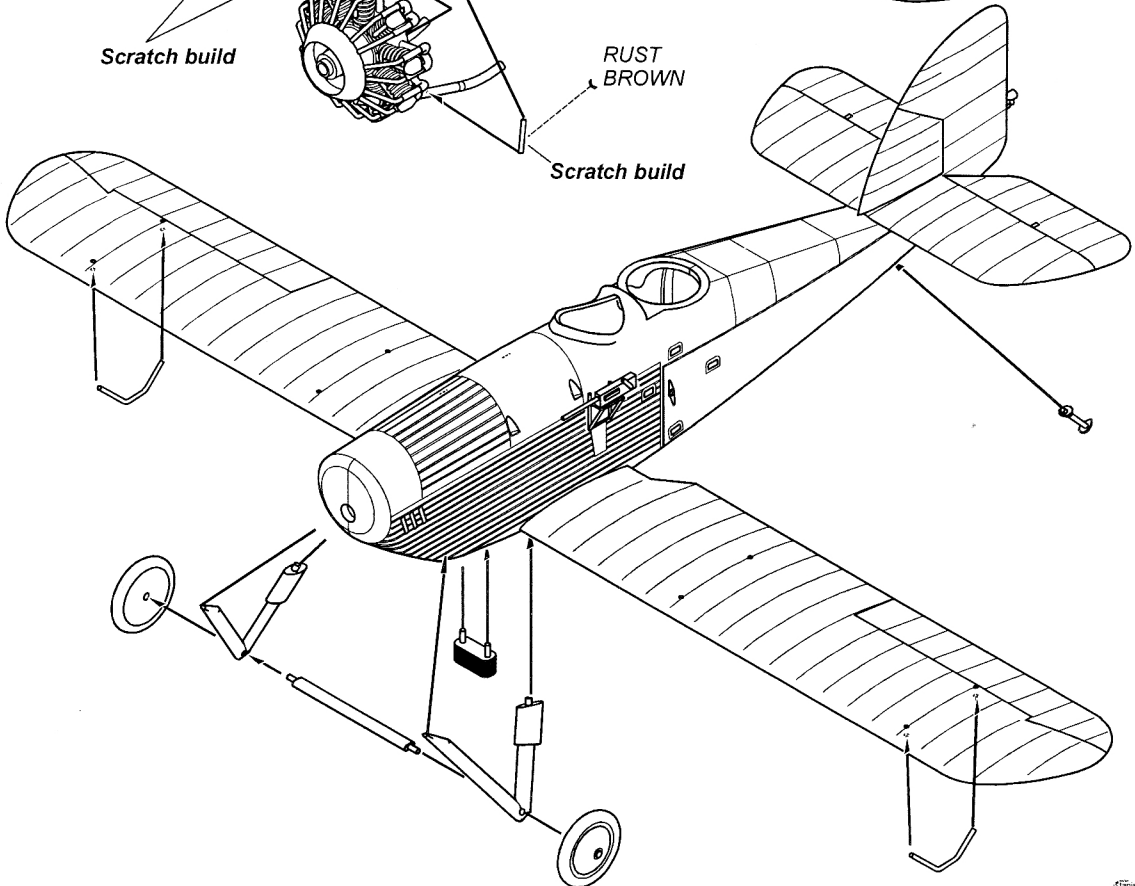

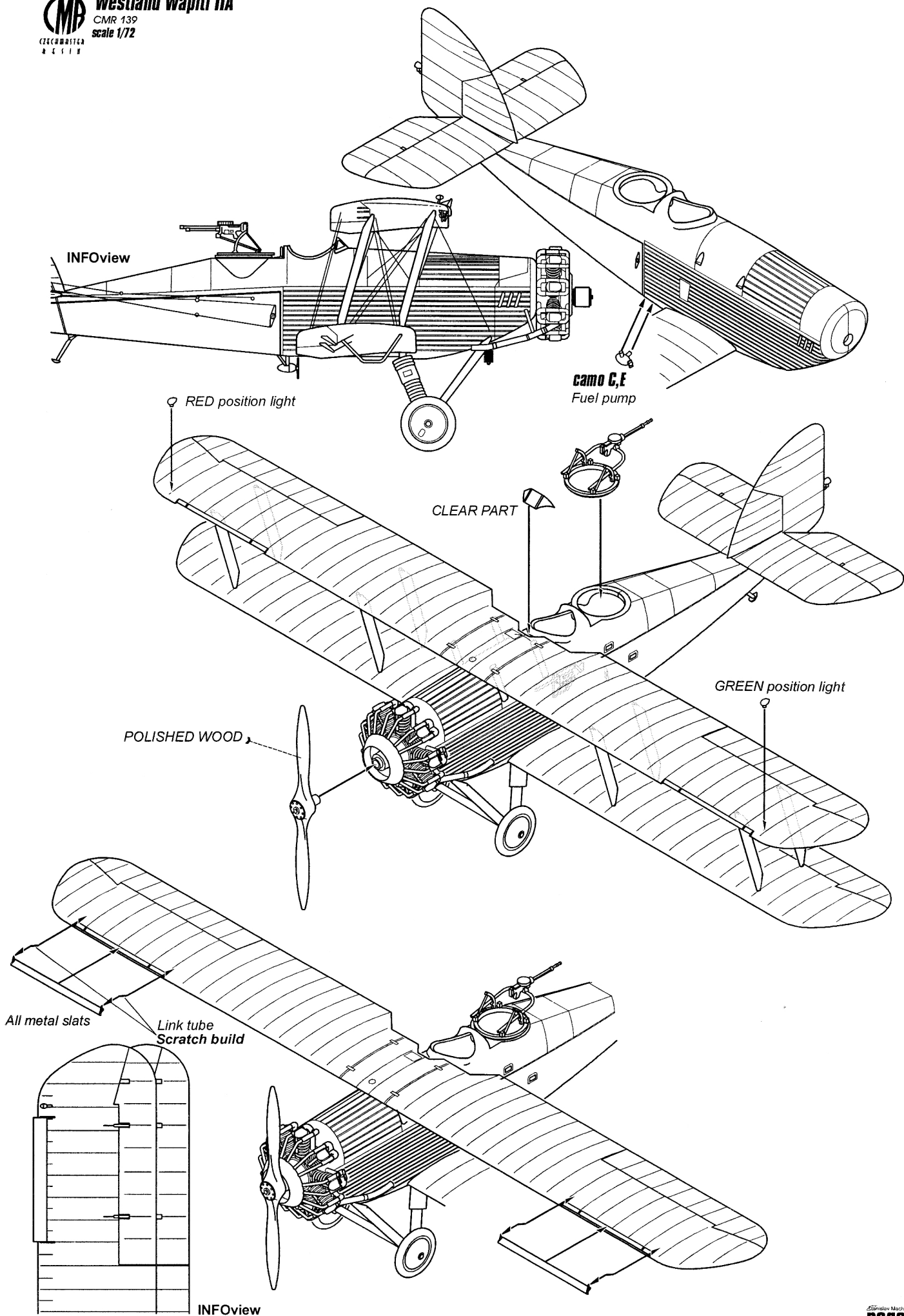



Westland Wapiti IIA

CMR 139
scale 1/72

CZECH REPUBLIC
A S T M

INFOview

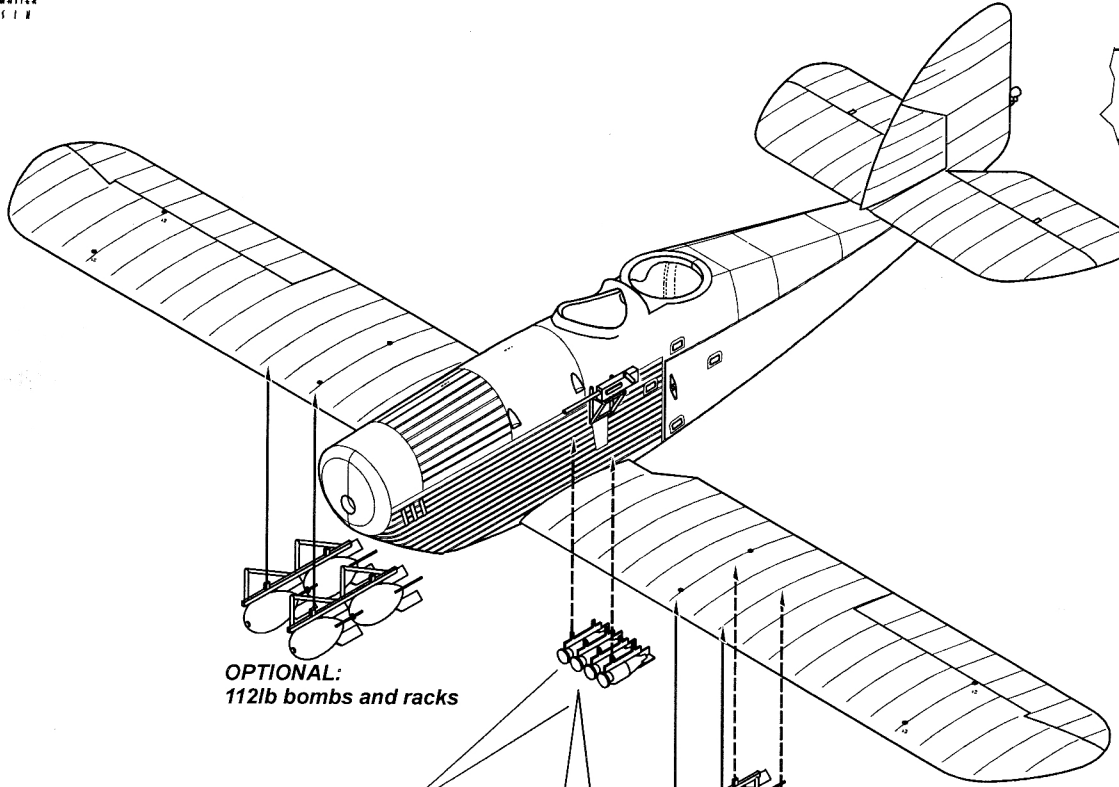
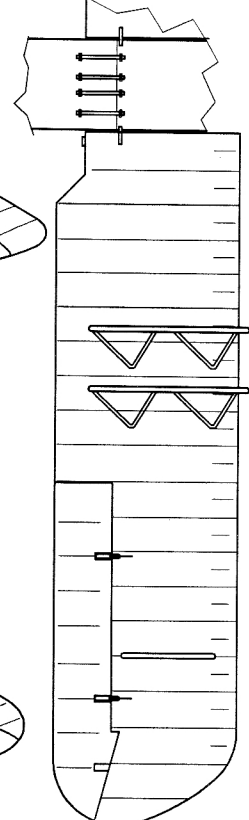

OPTIONAL:
112lb bombs and racks

OPTIONAL:
20lb bombs and racks

OPTIONAL:
112lb bombs and racks

Colour note:
The bombs were a light brownish yellow
on RAF interwar aircraft

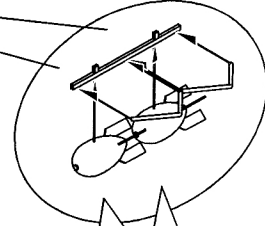
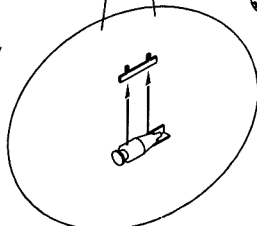

Scratch build
x 4 pcs

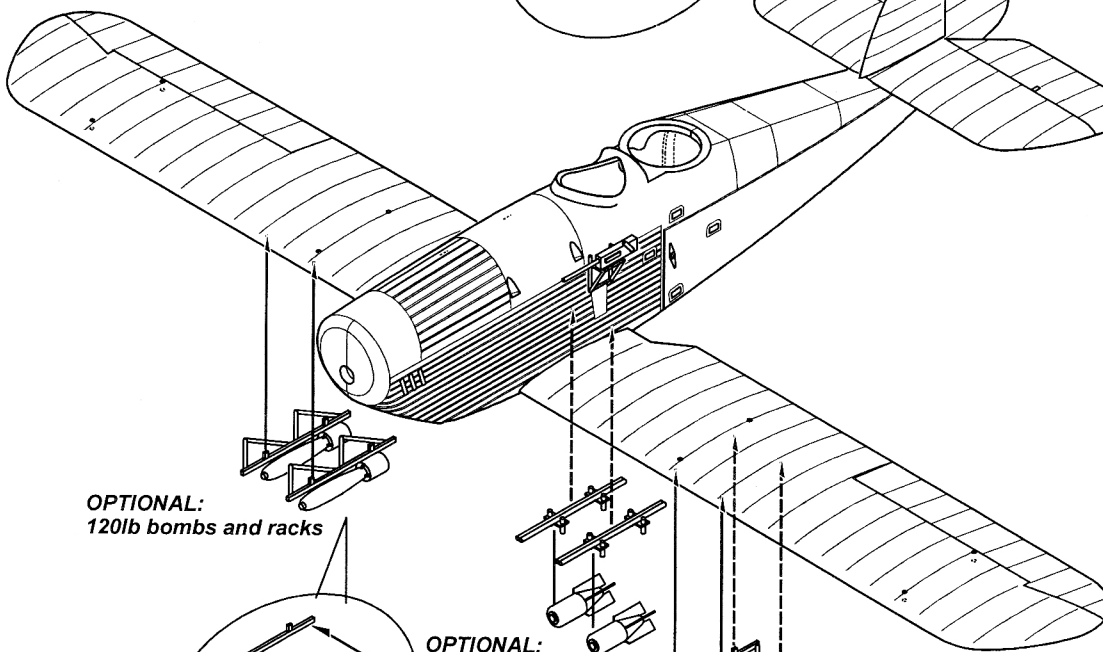

OPTIONAL:
120lb bombs and racks

OPTIONAL:
112lb bombs and racks

OPTIONAL:
120lb bombs and racks

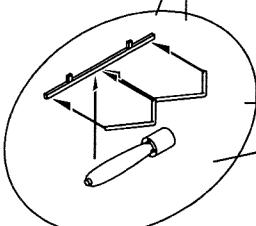

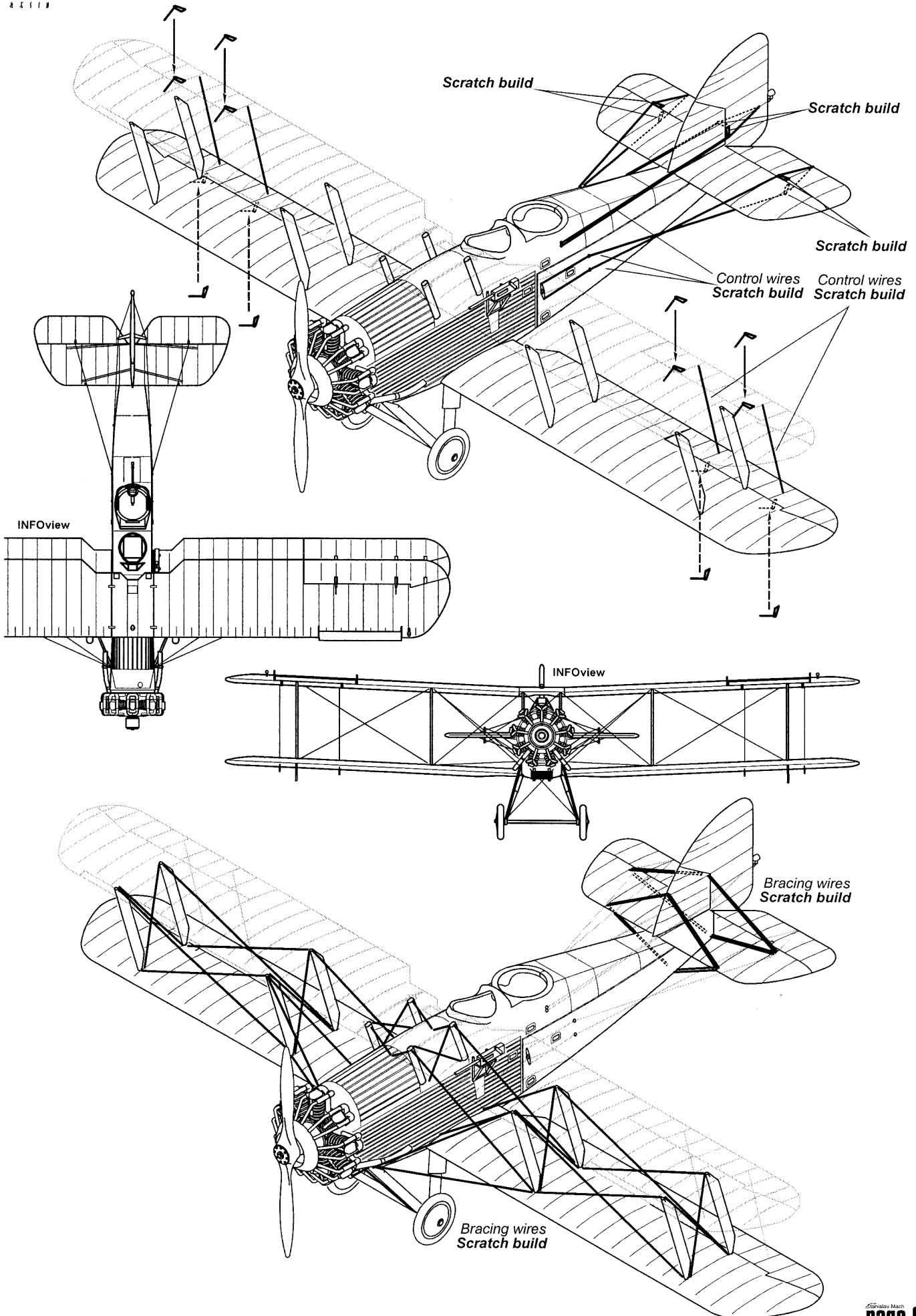

camo A Westland Wapiti IIA, K1291 of No.27 Squadron, Kohat, India, 1936.

The fuselage top was dark grey.

A red band appeared round the rear fuselage.

This is the commanding officer's aircraft and had his pennant fitted to the rear starboard outer wing strut.

Westland Wapiti IIA

scale 1/72

CMR 139

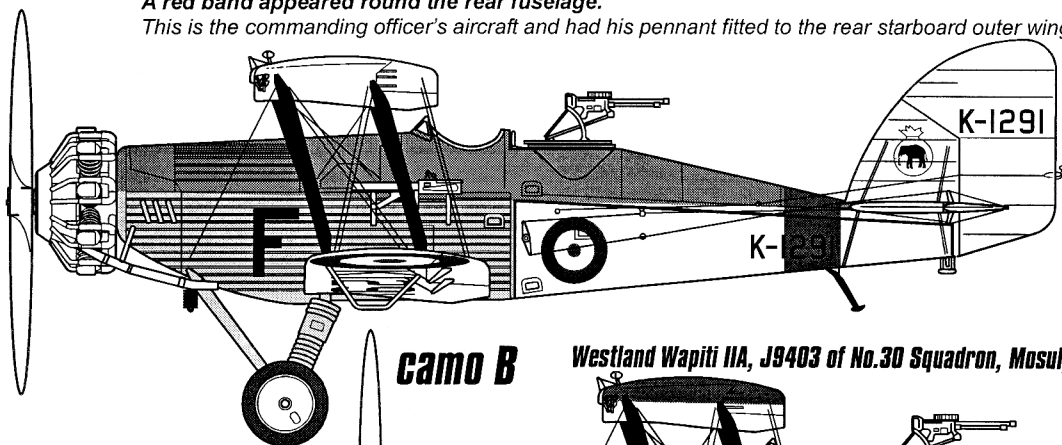

camo B

Westland Wapiti IIA, J9403 of No.30 Squadron, Mosul, Iraq, 1929.

BLUE WHITE RED.

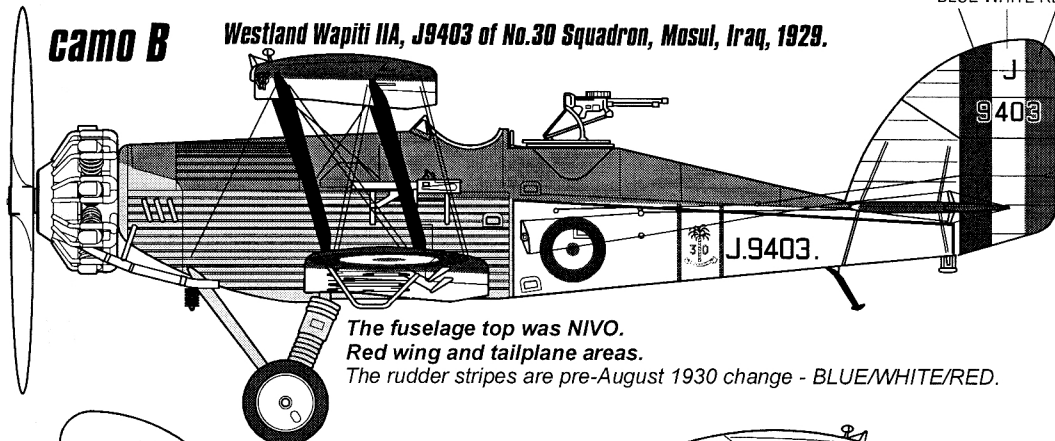

The fuselage top was NIVO.

Red wing and tailplane areas.

The rudder stripes are pre-August 1930 change - BLUE/WHITE/RED.

camo C

Westland Wapiti IIA,

K1336 of No.607

(County of Durham) Squadron,

Auxiliary Air Force, Usworth, 1935

The fuselage top was NIVO.

Wheel disc in flight colour - assumed to be RED.

Squadron badge on fin.

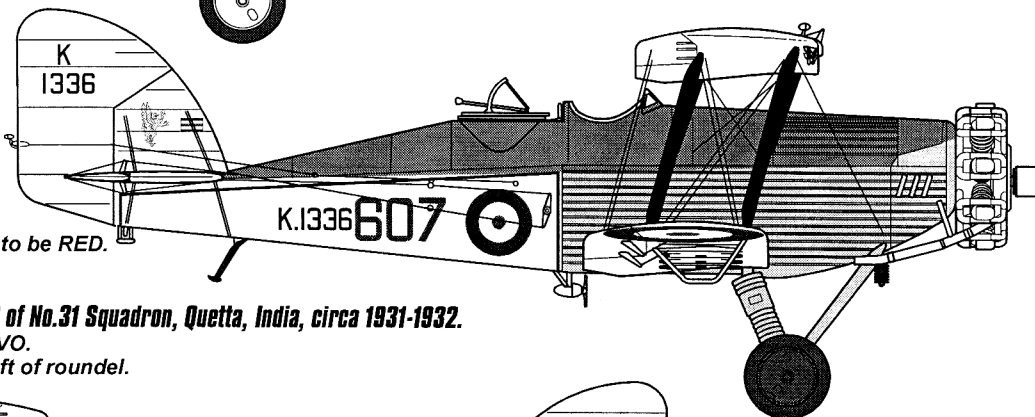

camo D Westland Wapiti IIA, J9388 of No.31 Squadron, Quetta, India, circa 1931-1932.

The fuselage top was NIVO.

Two vertical red bands aft of roundel.

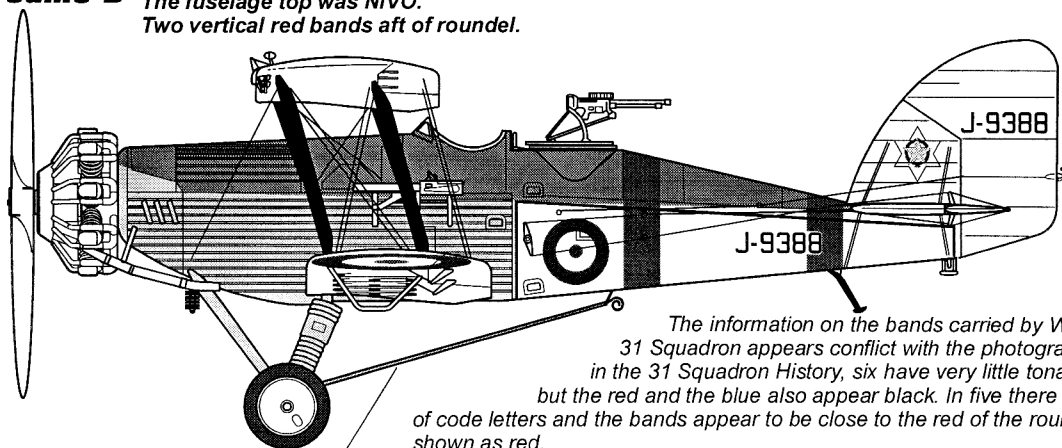

The information on the bands carried by Wapitis is very sparse and in the case of 31 Squadron appears conflict with the photographic evidence. Of eleven photographs in the 31 Squadron History, six have very little tonal contrast and the bands appear black, but the red and the blue also appear black. In five there is a distinct contrast between the black of code letters and the bands appear to be close to the red of the roundel in tone - they have therefore been shown as red.

Scratch build
Message Hook

camo E

Westland Wapiti IIA,

K1342 of No.601

(County of London) Squadron,

Auxiliary Air Force, Hendon, Middlesex,

June 1932

The fuselage top was NIVO.

Wheel disc in flight colour - RED.

The rudder stripes are RED/WHITE/BLUE.

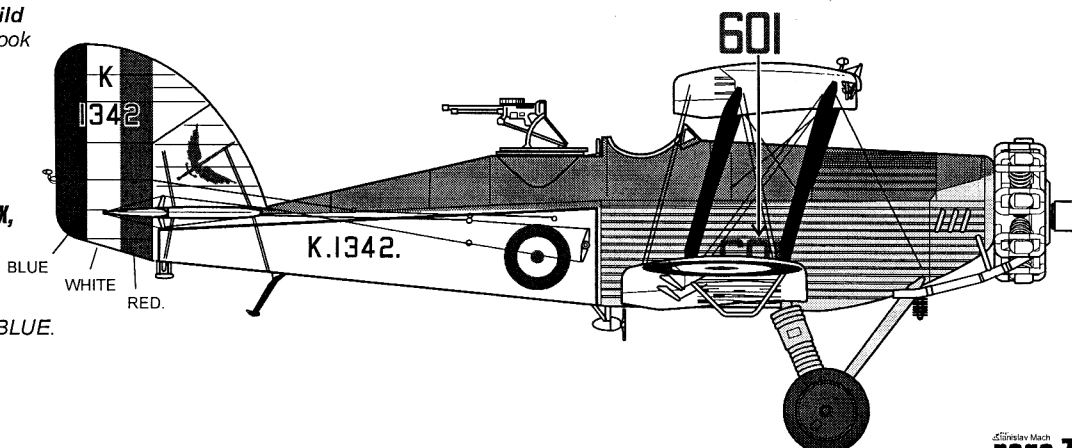

Westland Wapiti IIA

CMR scale 1/72
 CMR 139
 CZECH REPUBLIC

camo A,C,D,E

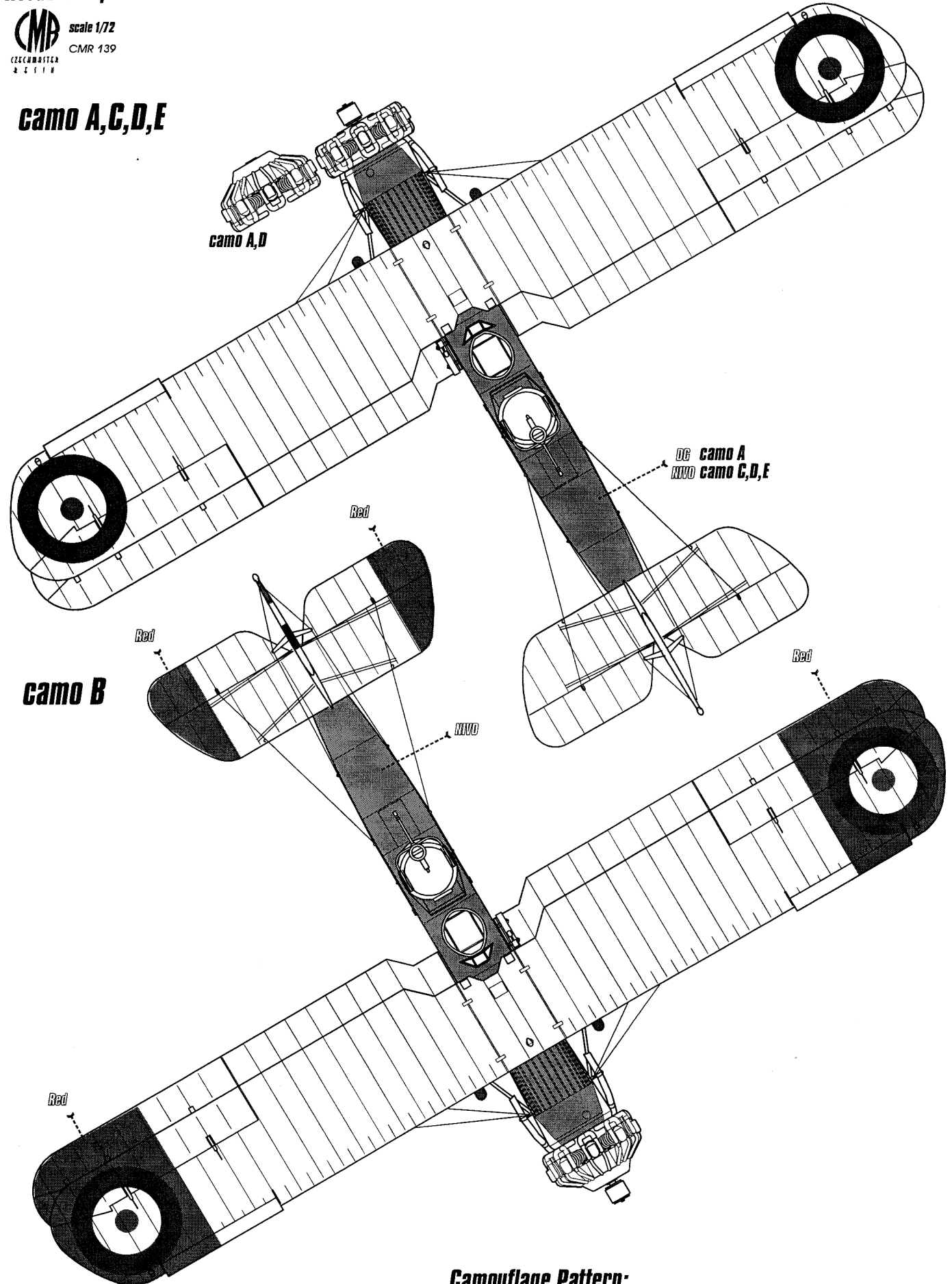

camo B

Federal Standard FS 595A colour match: Colour code

- | | | |
|--------------------------------|----------|------|
| Dark Grey | FS 38173 | DG |
| NIVD (Night Invisible Varnish) | FS 34096 | NIVD |
| Red | FS 11302 | Red |

Camouflage Pattern:

The wings, rear fuselage, and tail unit were painted SILVER, whilst the undercarriage legs, and forward fuselage were NATURAL METAL. The fuselage top was NIVD or DARK GREY. Struts, oil cooler and bomb racks were painted BLACK.

Westland Wapiti IIA

CMR scale 1/72
CMR 139

camo A,C,D,E

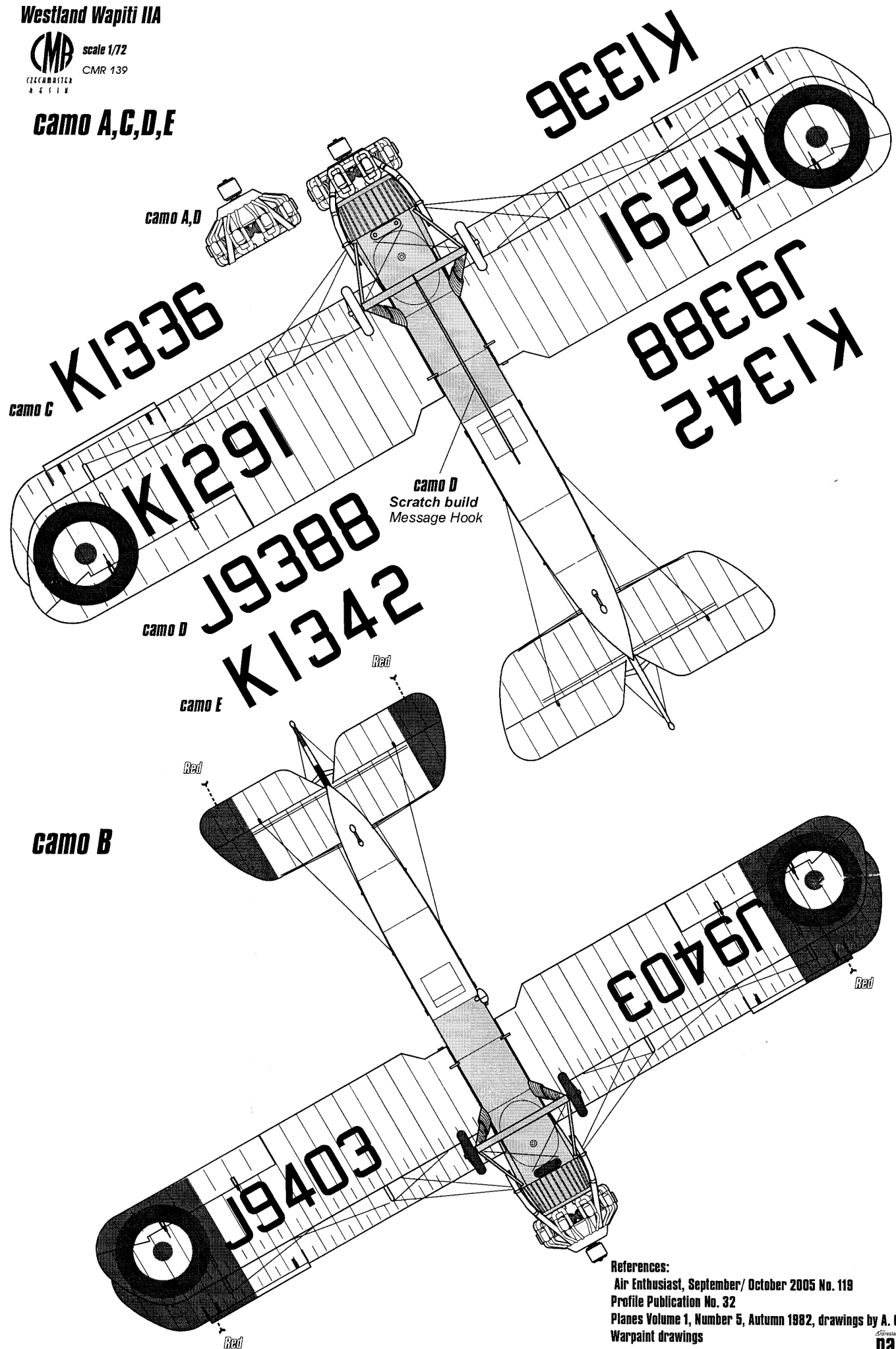

References:
 Air Enthusiast, September/ October 2005 No. 119
 Profile Publication No. 32
 Planes Volume 1, Number 5, Autumn 1982, drawings by A. Granger
 Warpaint drawings