

HS/BAE.748 SRS.2B

SUPER 748

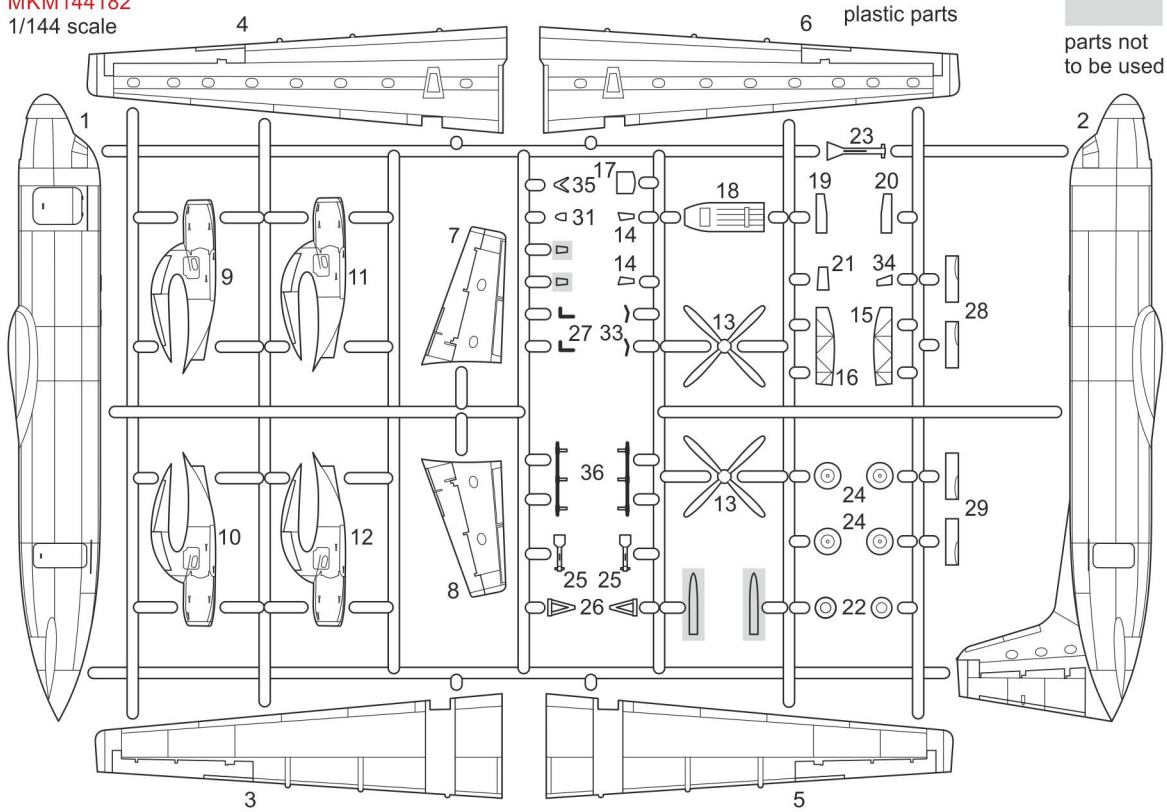

MKM144182
1/144 scale



MARK I Ltd.
PO Box 10
Prague 10 - Strašnice
CZ-100 31
Czech Republic
mark1@gmail.cz
www.4pluspublications.com

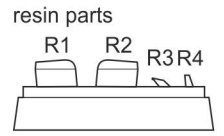

display base
(use the bottom of the box)

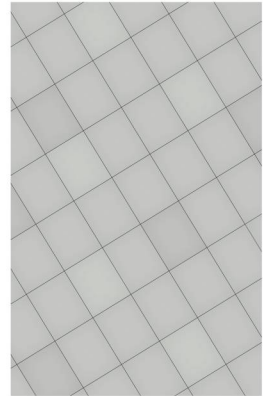

- Repeat this operation
- Glue
- Don't glue
- Decal
- Detach/cut
- Bend
- Drill
- Optional

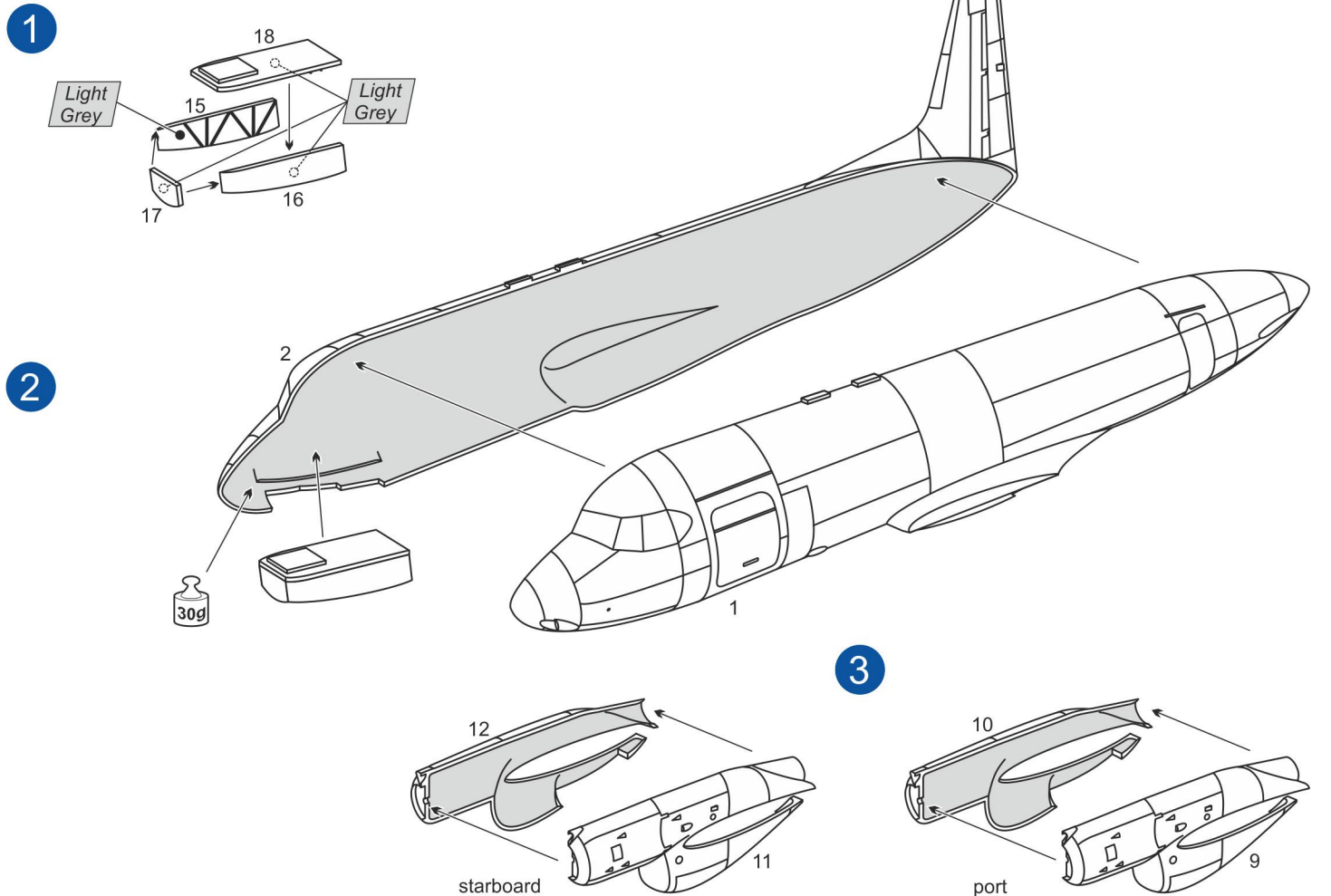

4

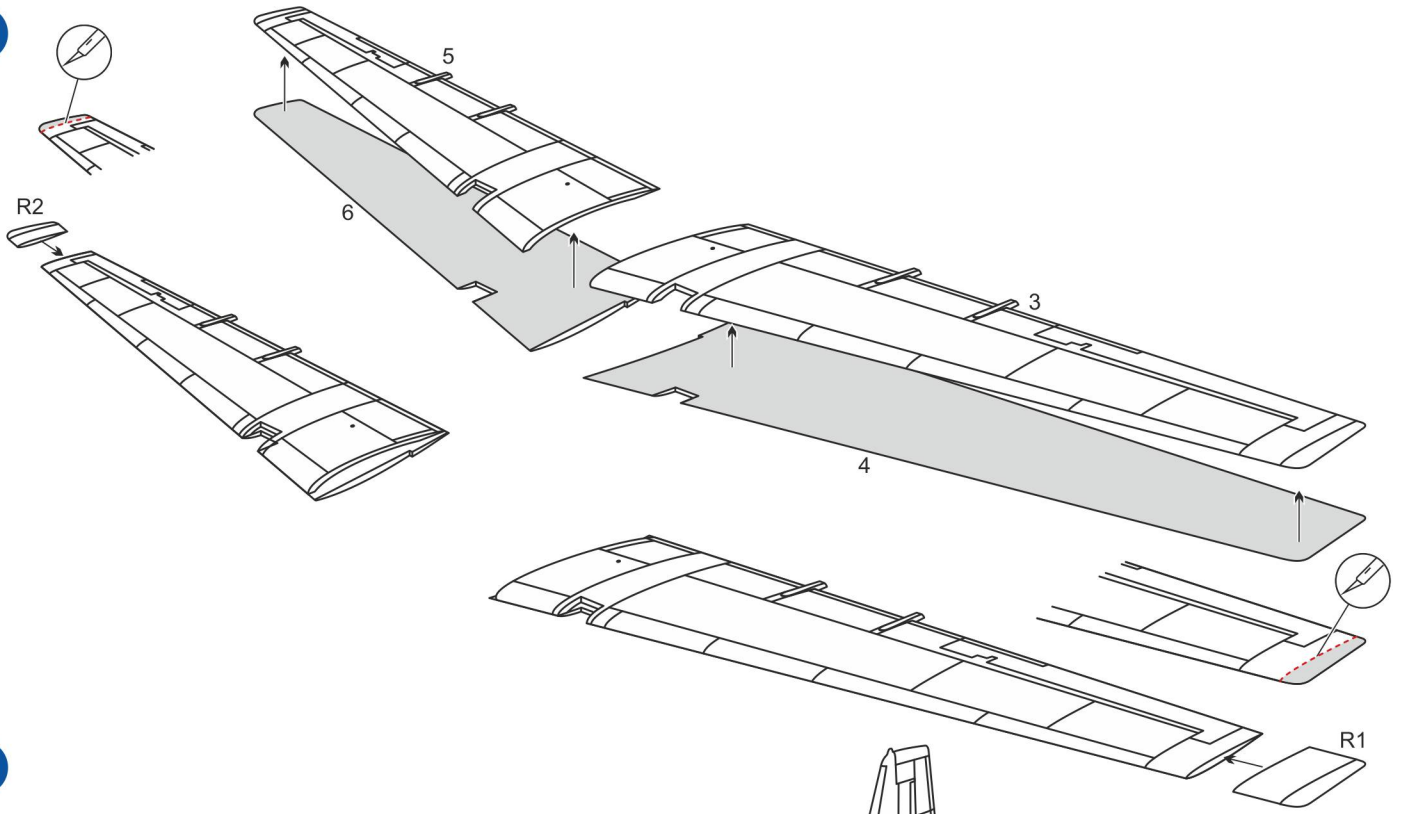

5

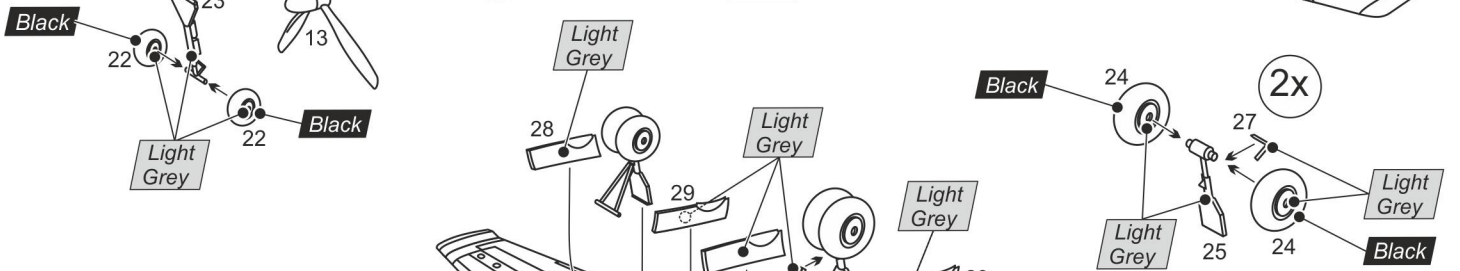
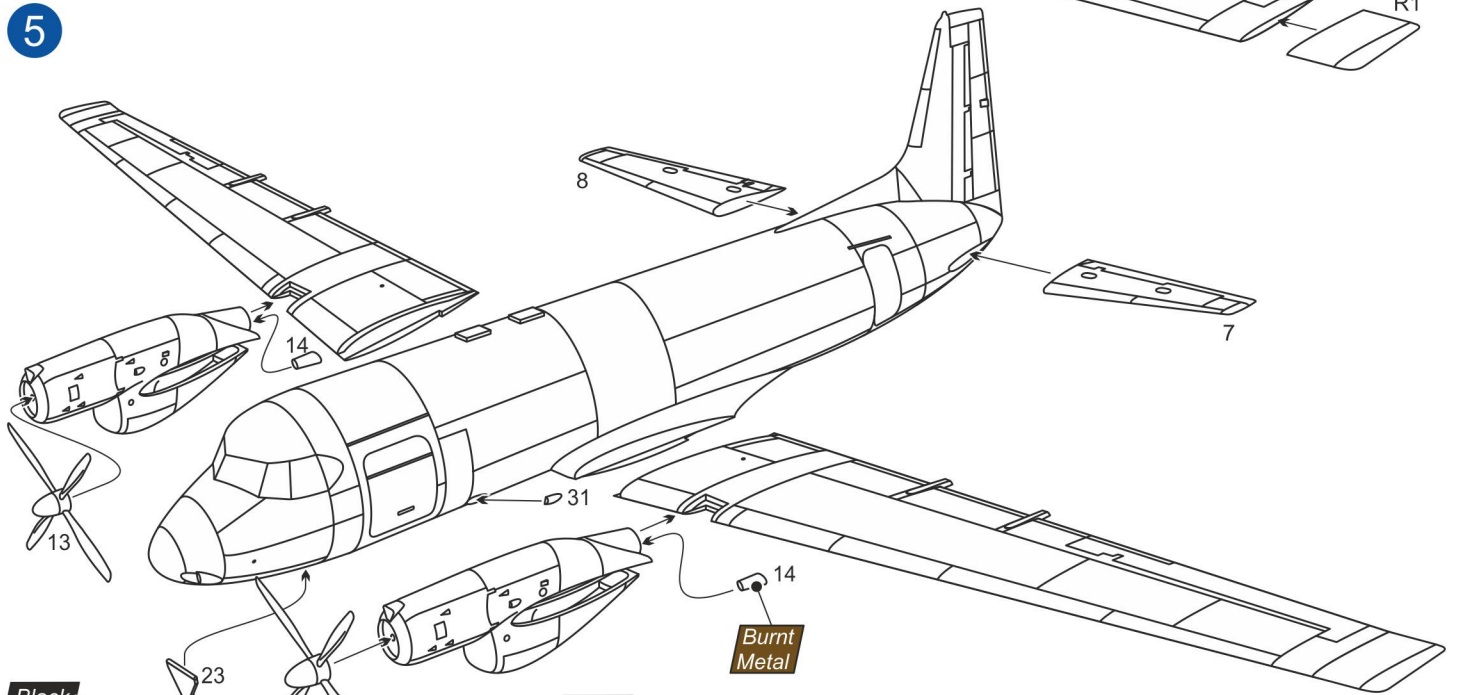

6

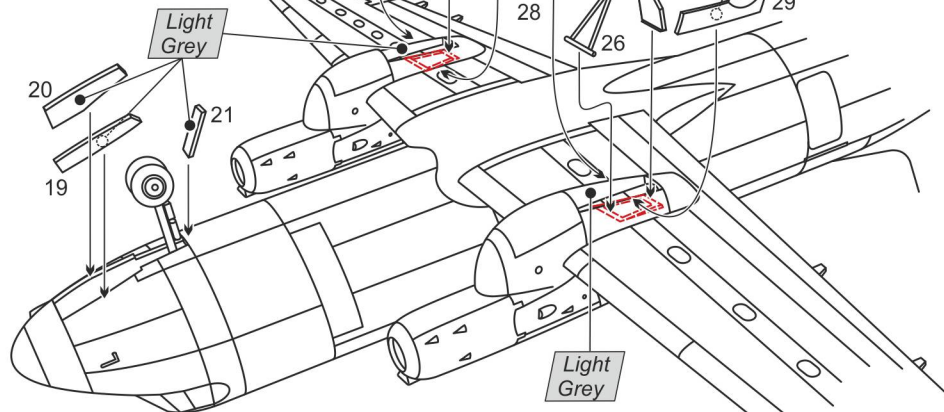

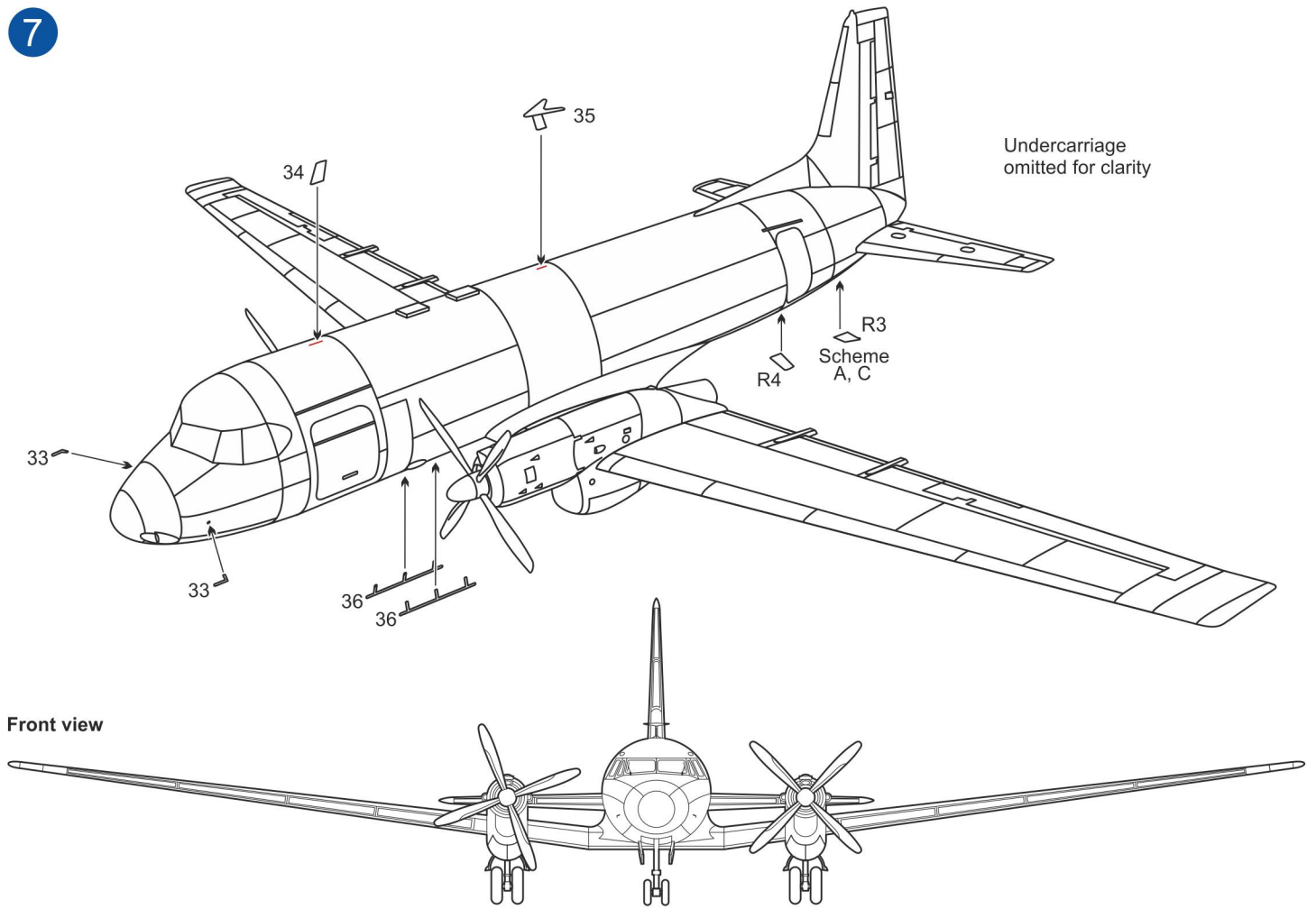

A British Aerospace BAe.748 (Srs.2B Model 378), G-HDBD (c/n 1797), British Airways Ltd., flown between various regional airports, U.K., 1990-92

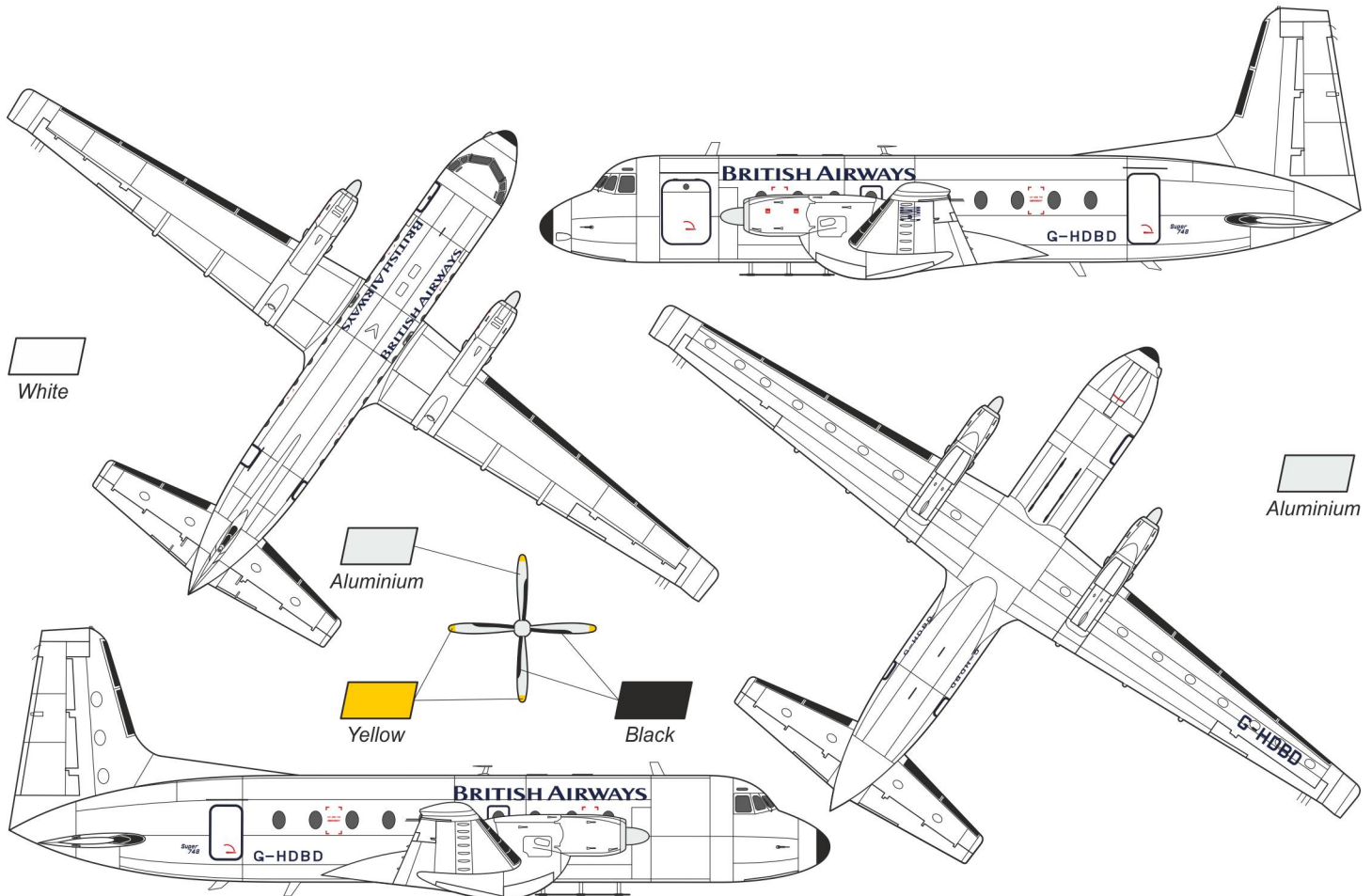

B Hawker Siddeley HS.748 (Srs.2B Model 287), G-BCOF (c/n 1737), 'Glen Fiddich/Gleann Fithich', British Airways Ltd., flown between various regional airports, U.K., 1985-94

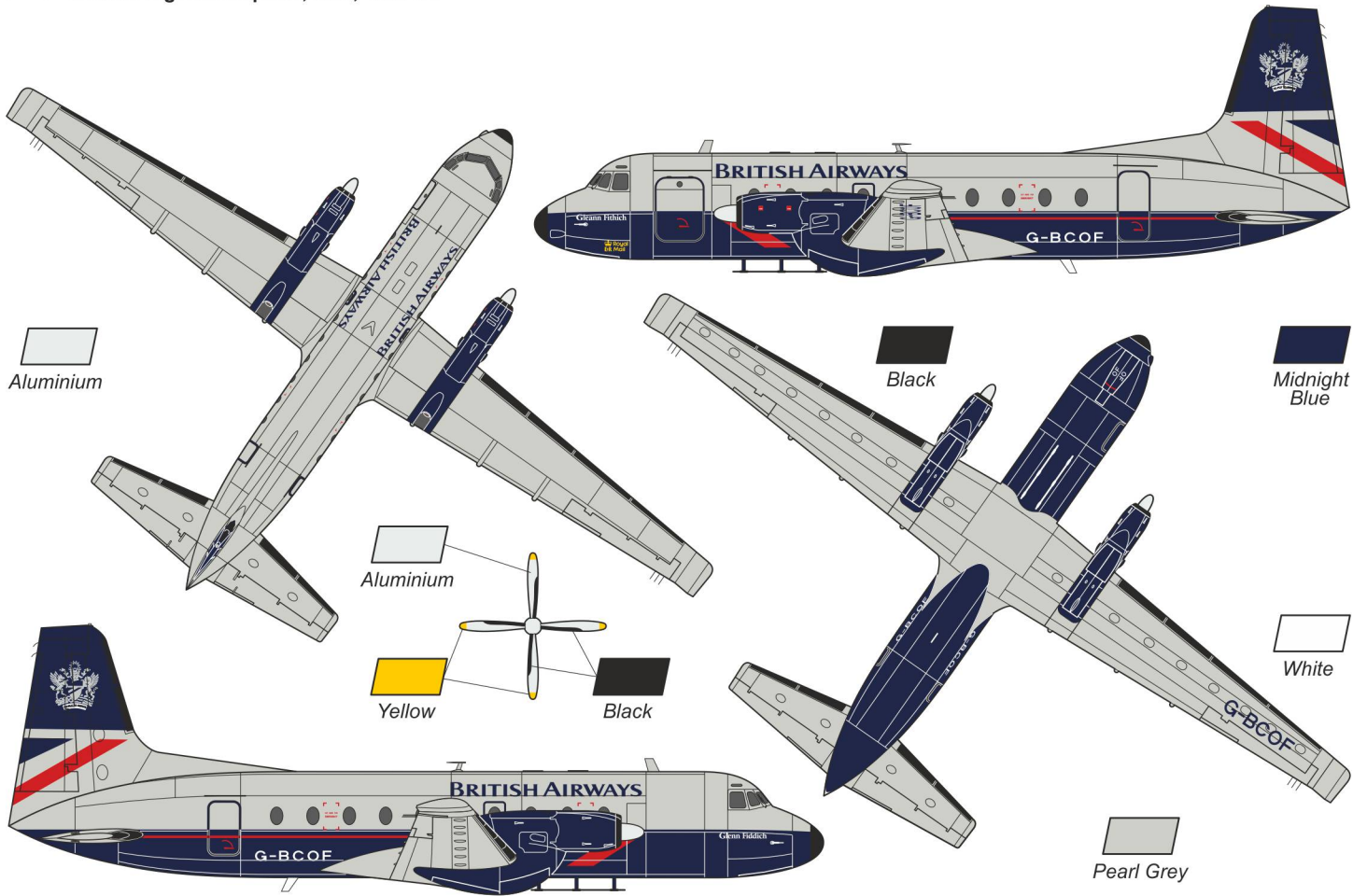

C Hawker Siddeley HS.748 (Srs.2B Model 378), G-BOHZ (c/n 1785), for service with Goa Way Aviation (India's Holiday Airline), Prestwick Airport, Scotland, U.K., 1993-94

