

# DE HAVILLAND MOSQUITO B.VII/XX/F-8

## CANADIAN MOSSIE



MKM14485  
1/144 scale

parts not  
to be used

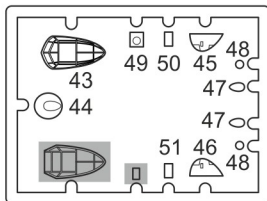

clear parts

MARK I Ltd.  
PO Box 10  
CZ-100 31 Prague 10  
Czech Republic  
mark1@gmail.cz  
www.4pluspublications.com

plastic parts

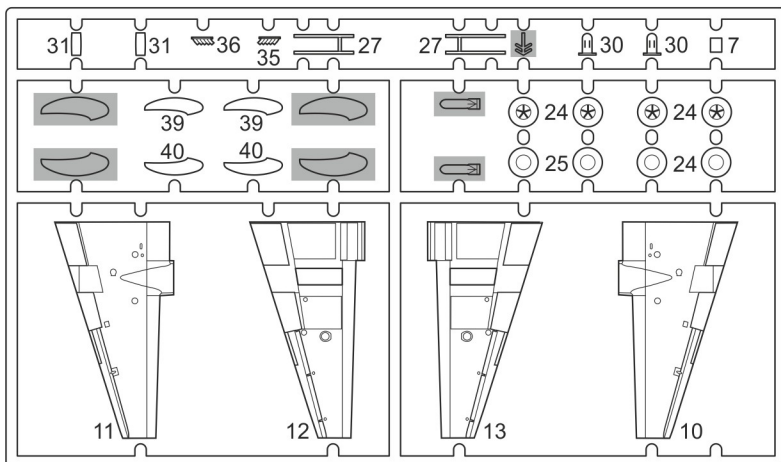
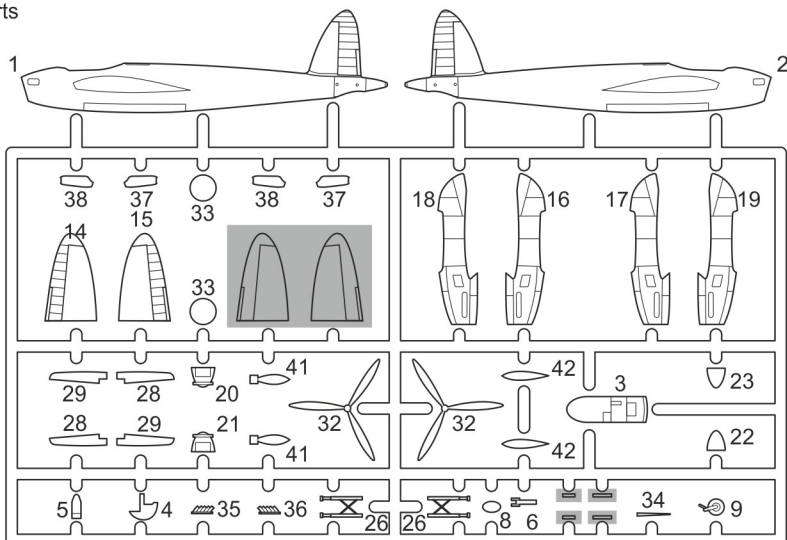

2x Repeat this operation

Glue

Decal

Drill

Detach/cut

Optional

1

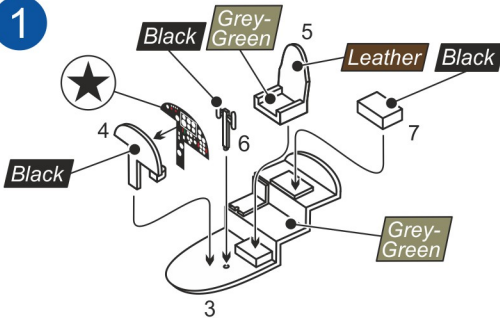

2

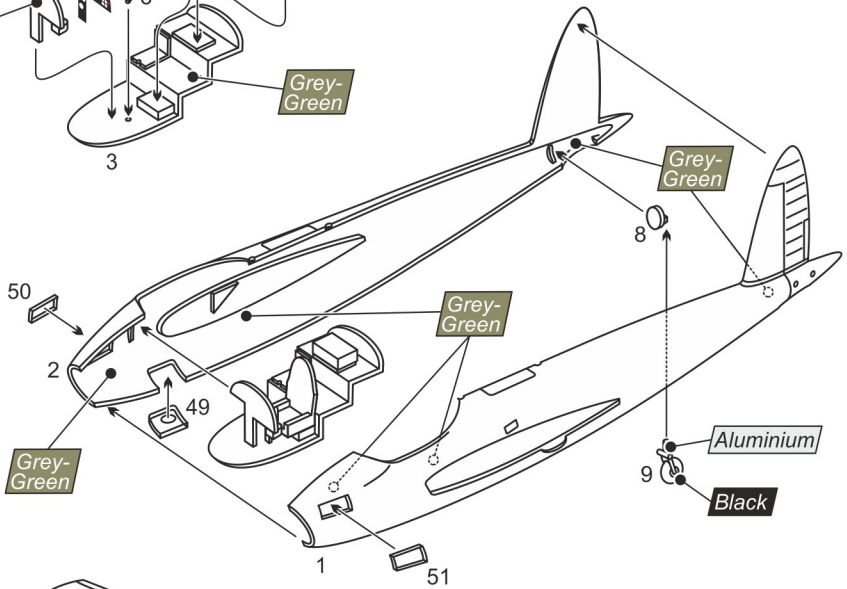

3

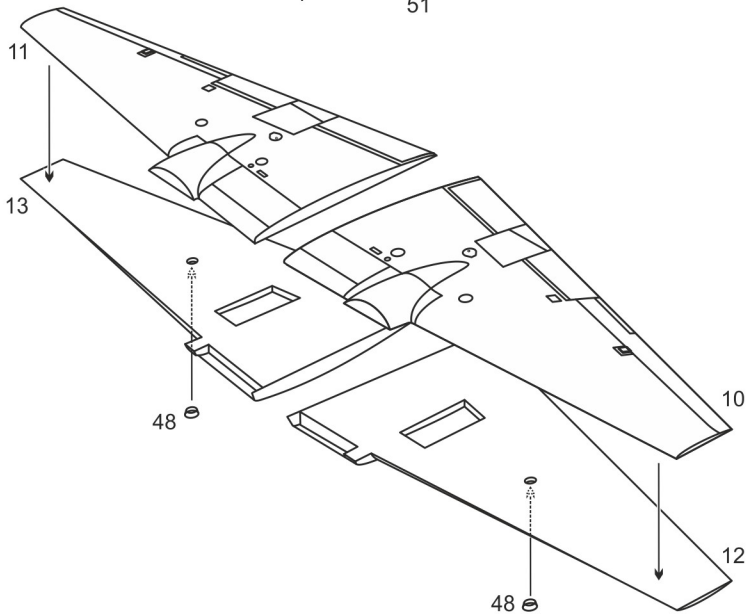

4

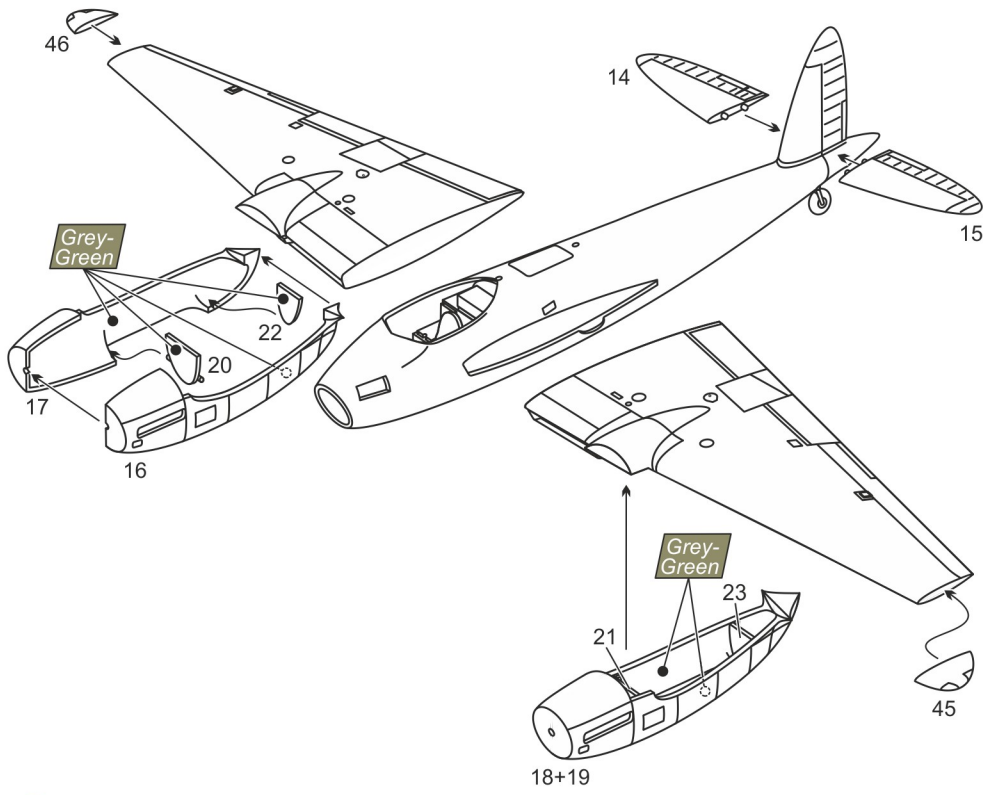

5

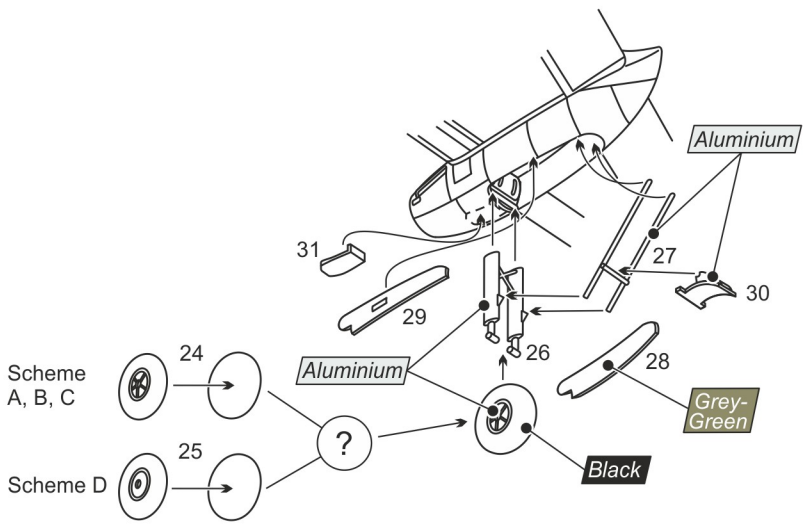

6

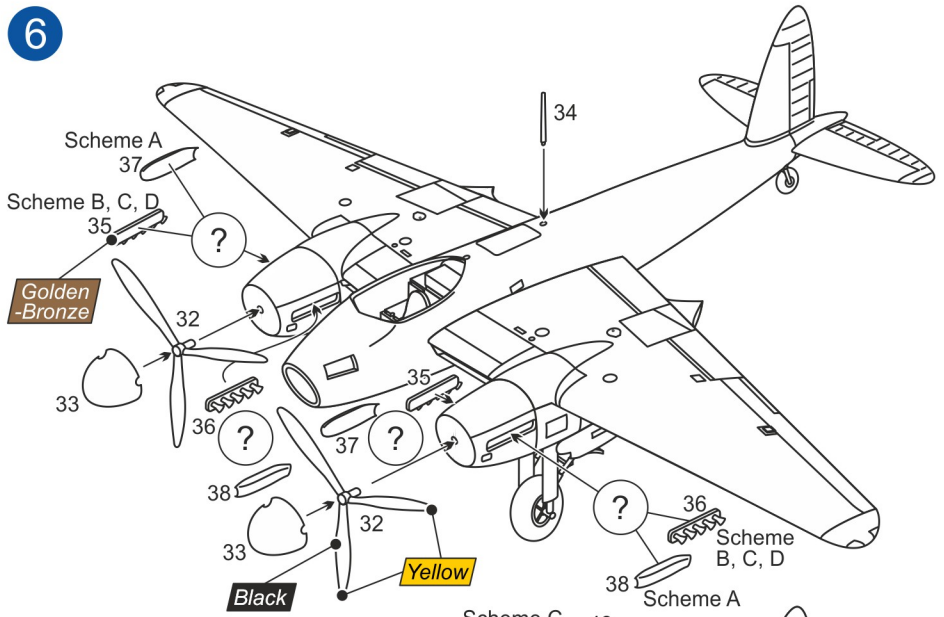

7

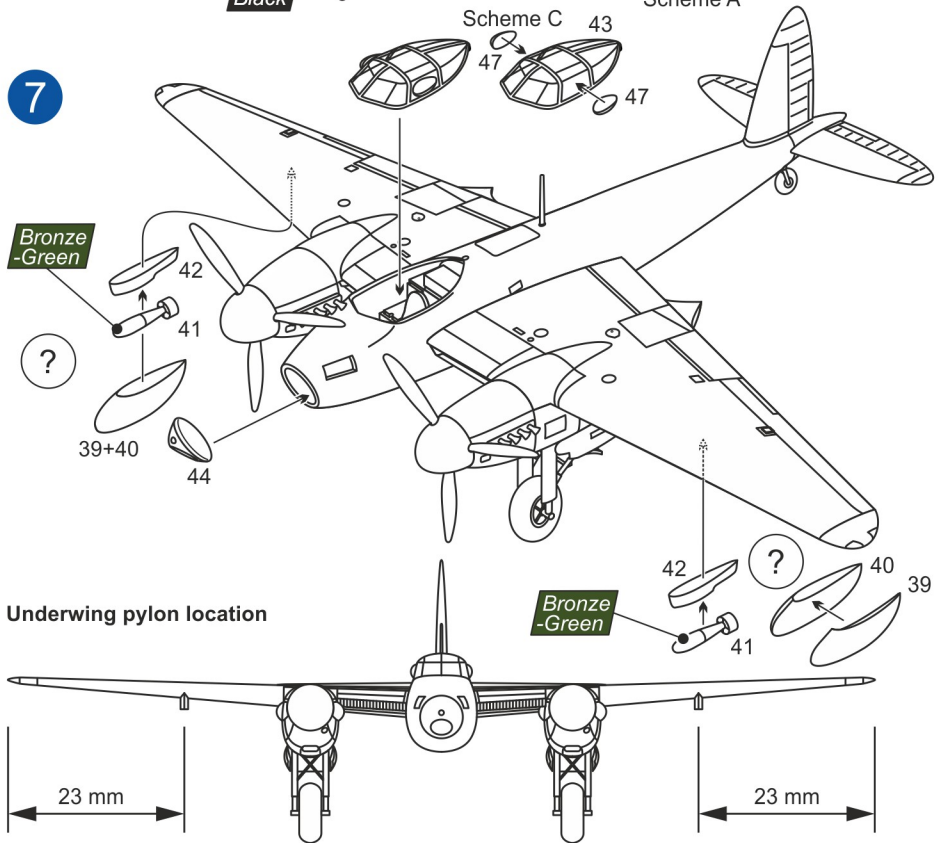

A

de Havilland DH.98 (de Havilland of Canada) Mosquito B Mk.VII, KB300, Royal Canadian Air Force, Downsview airfield, Toronto, Ontario, Canada, September 1942

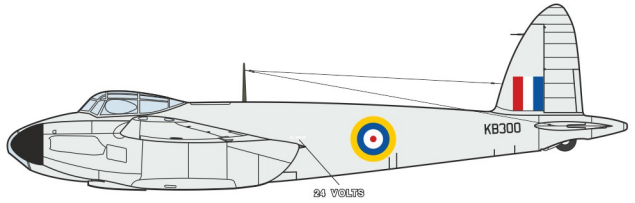
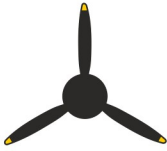

54 VOLTS



Black

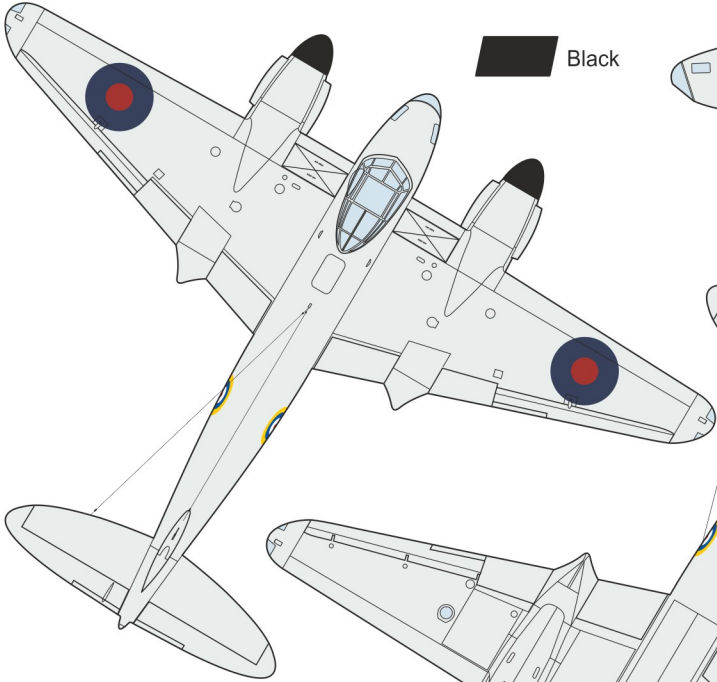
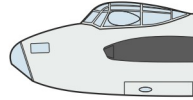

Aluminium

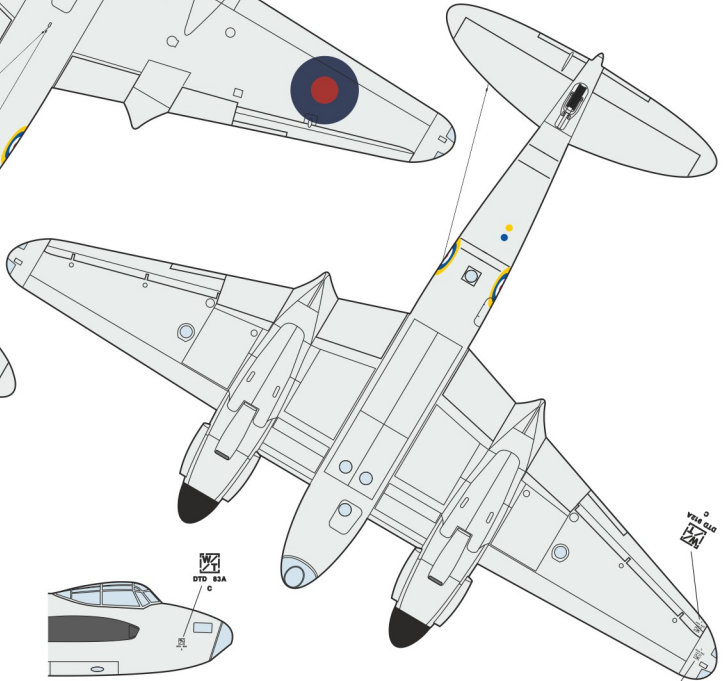

V21 121  
DTD 83A  
C

V21 121  
DTD 83A  
C

V21 121  
DTD 83A  
C

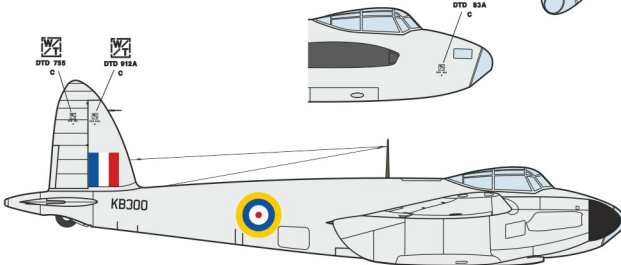

V21 121  
DTD 755  
C

V21 121  
DTD 915A  
C





de Havilland DH.98 (de Havilland of Canada) Mosquito B Mk.XX, KB288, White VI-46, No.7 OTU, Royal Canadian Air Force, Debert airfield, Nova Scotia, Canada, October 1944

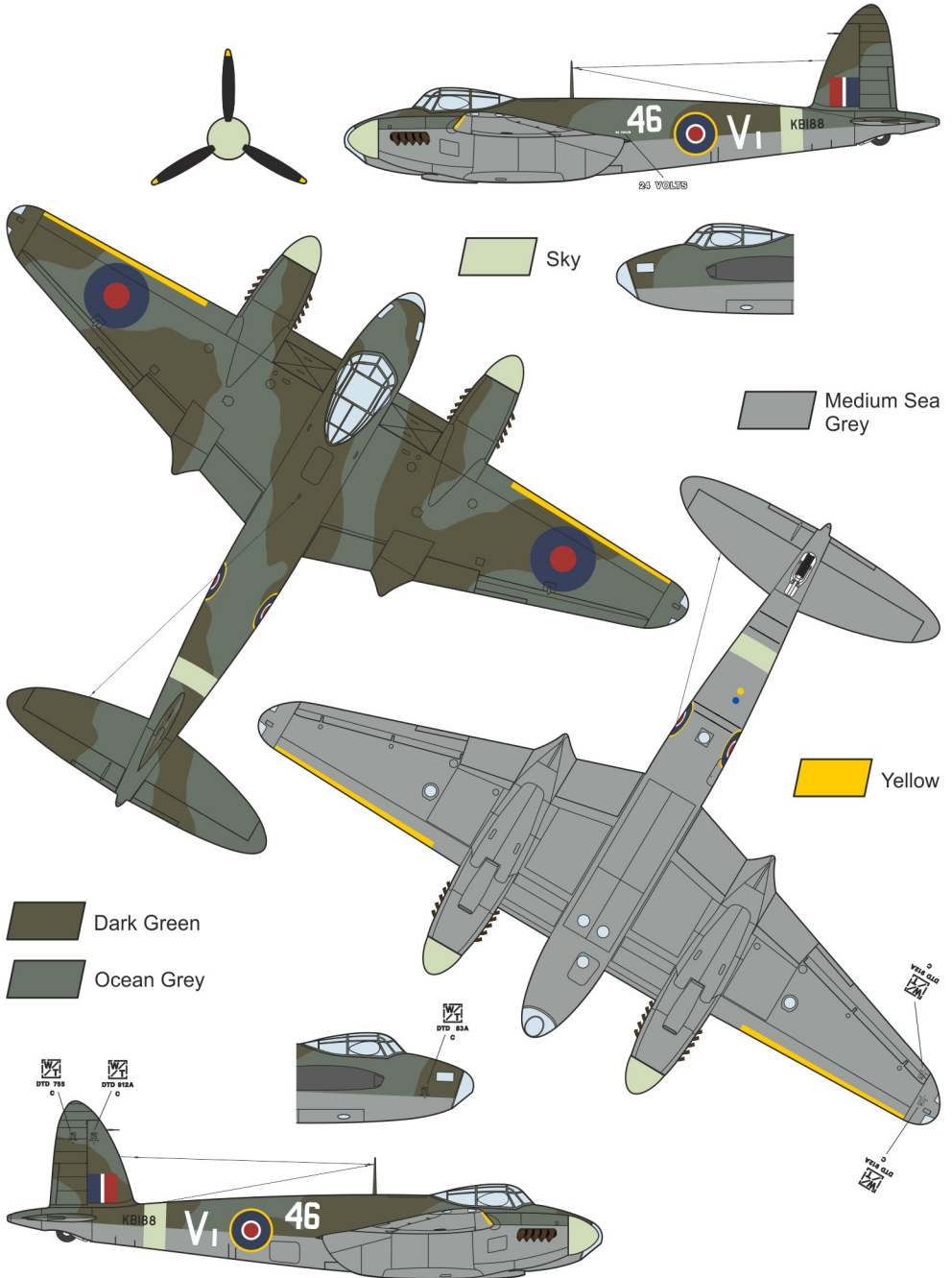



de Havilland DH.98 (de Havilland of Canada) Mosquito F-8, s/n 43-34926 (ex-KB315), Yellow 334926, 'The Spook', 3rd Photographic Group (Reconnaissance), USAAF, La Marsa airfield, Tunisia, North Africa, November 1943

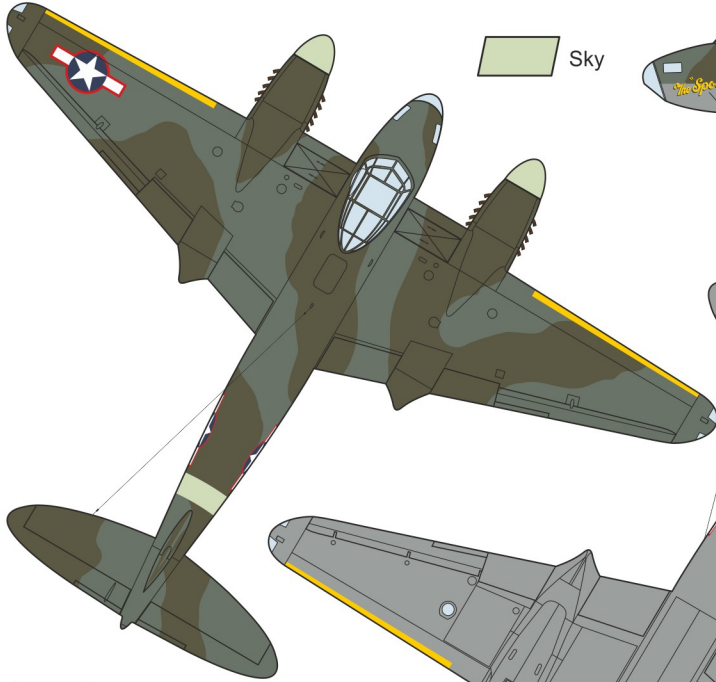
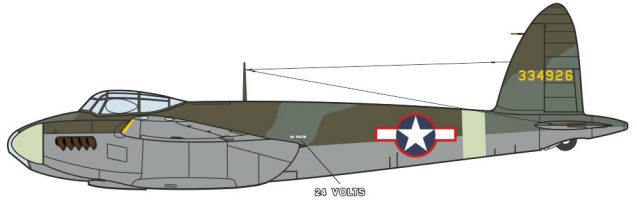
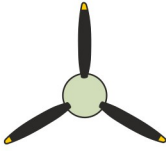

Sky



*The "Spook"*

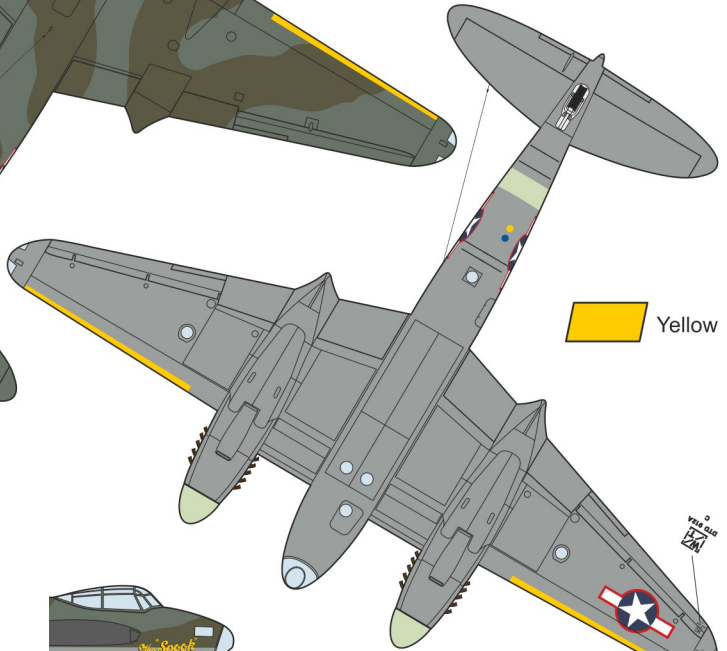
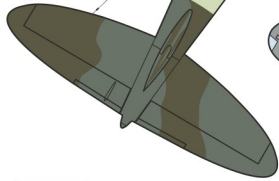

Yellow

-  Dark Green
-  Ocean Grey
-  Medium Sea Grey



*The "Spook"*

