

AVRO 748/HS.748

THE BUDGIE

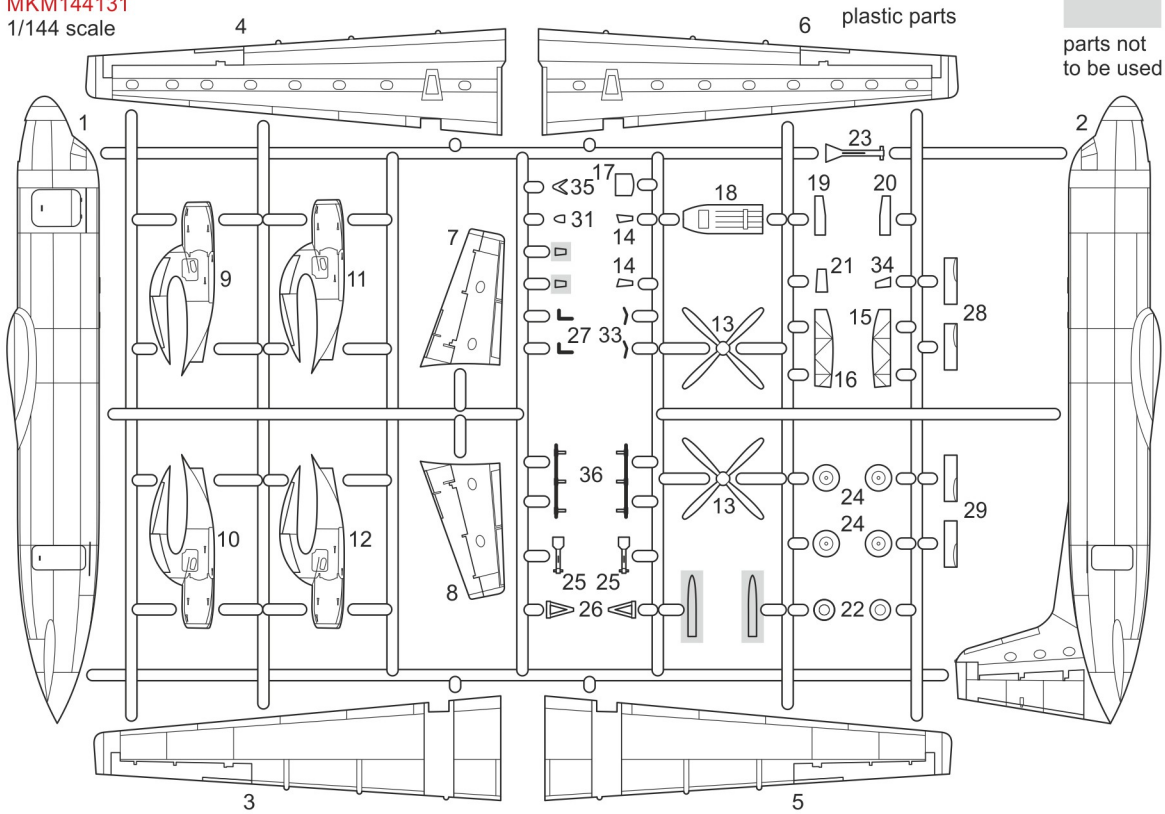

MKM144131
1/144 scale



MARK I Ltd.
PO Box 10
Prague 10 - Strašnice
CZ-100 31
Czech Republic
mark1@gmail.cz
www.4pluspublications.com

display base

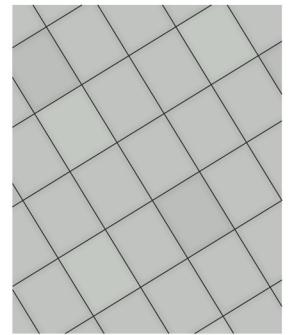

- 2x Repeat this operation
- Glue
- Don't glue
- Decal
- Detach/cut
- Bend
- Drill
- ? Optional

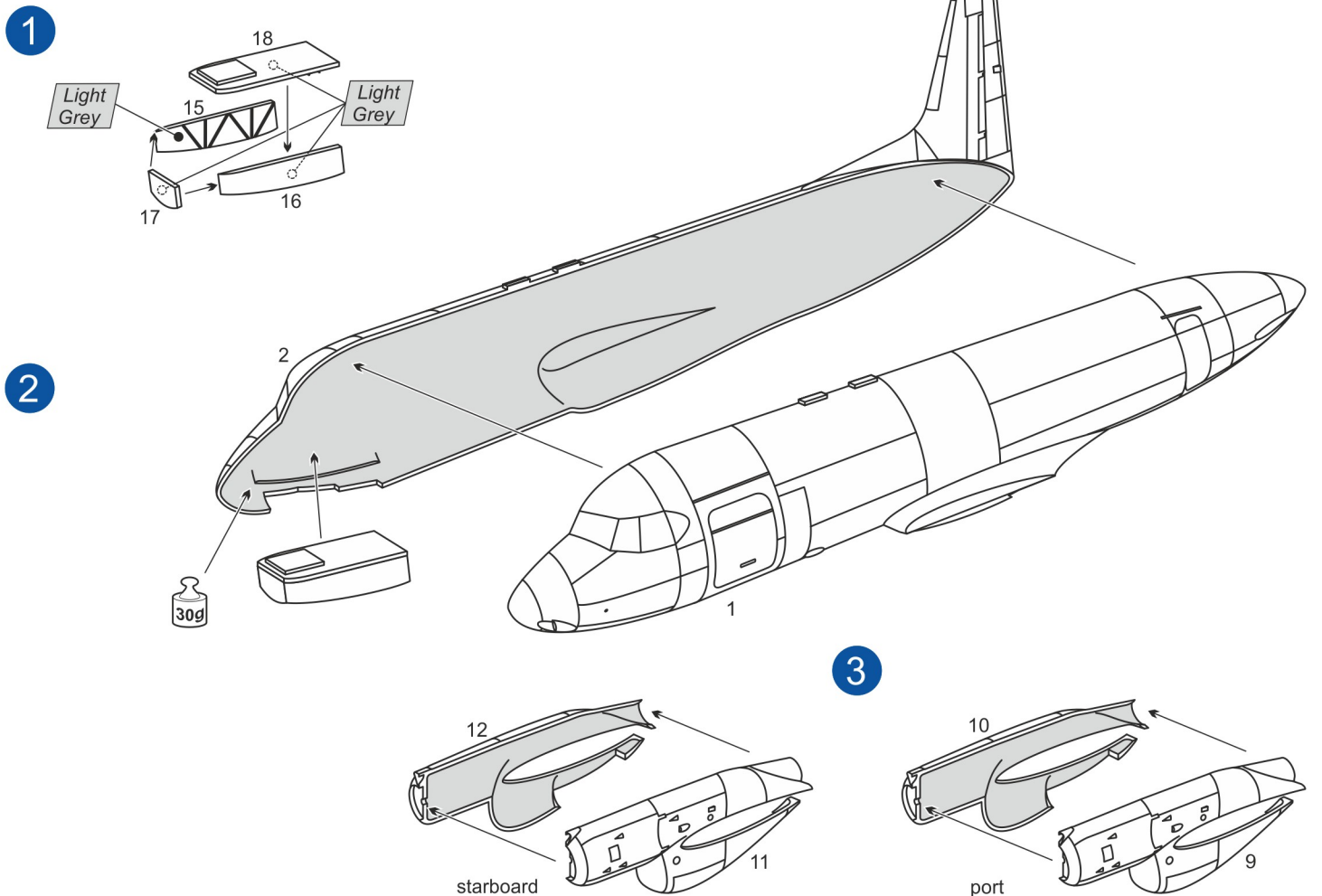

4

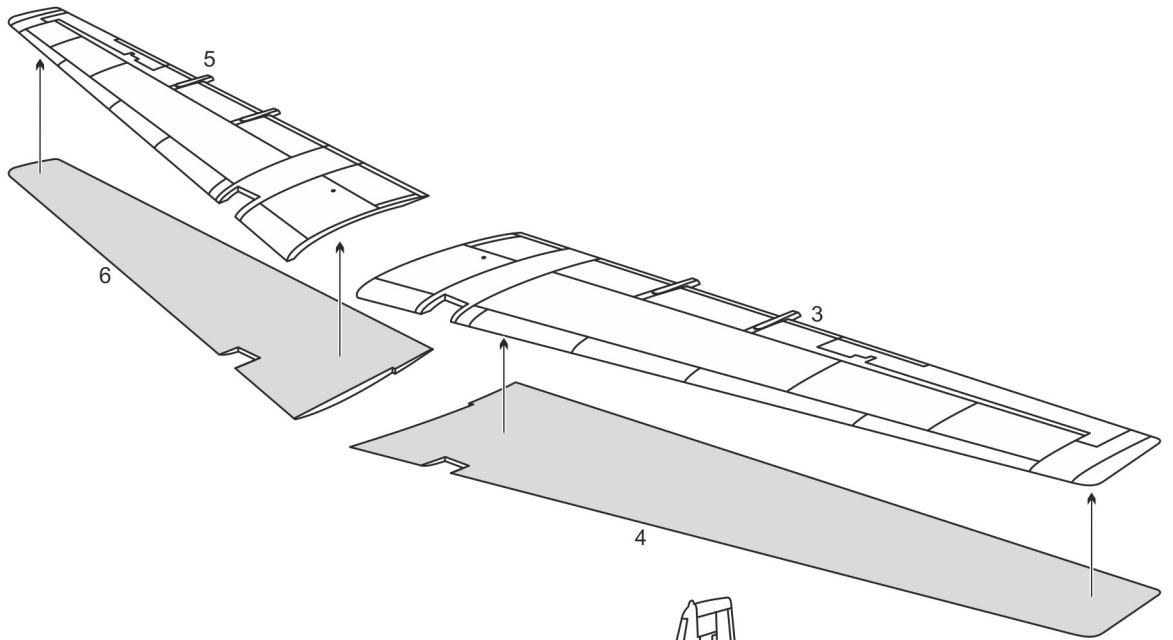

5

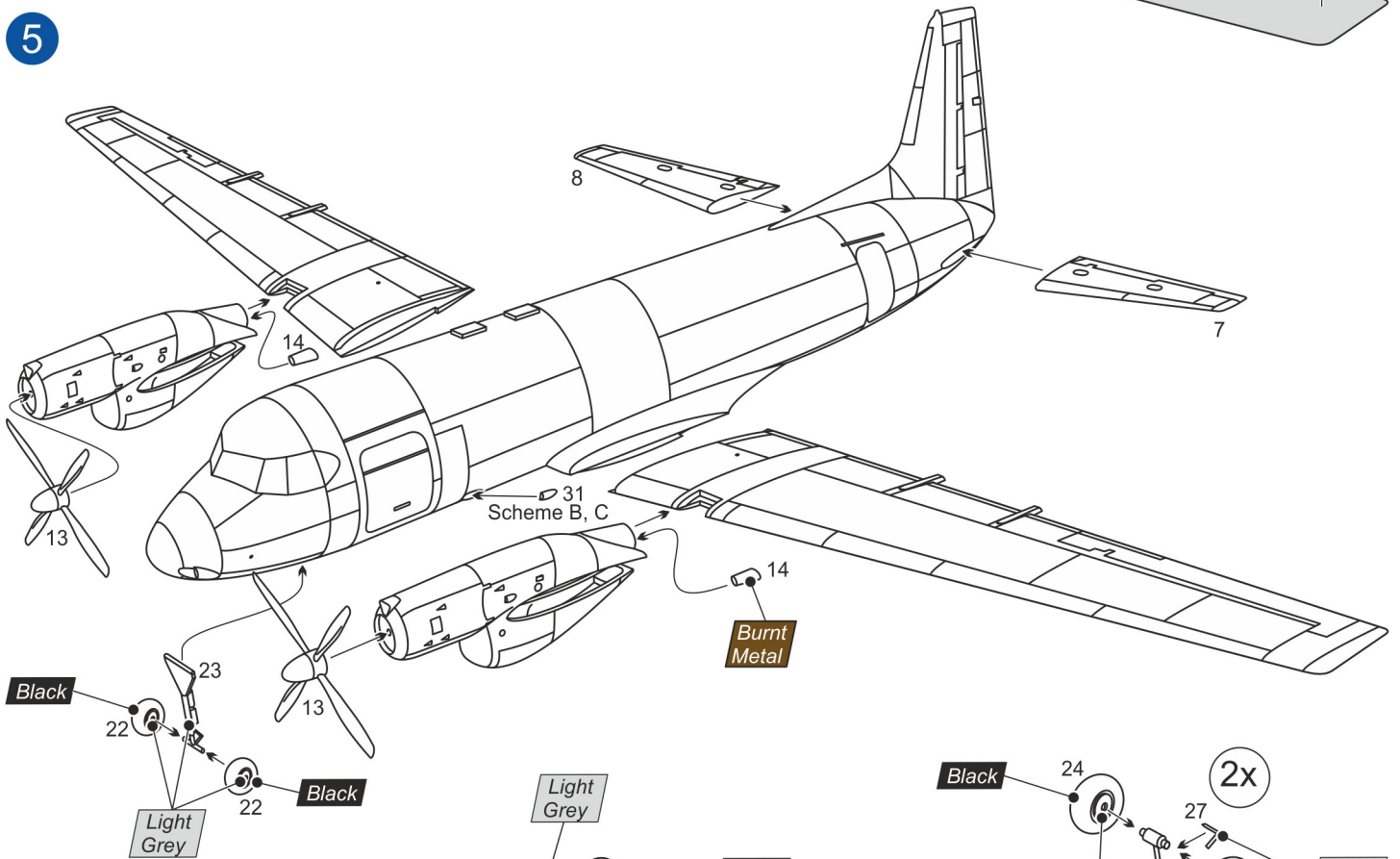

6

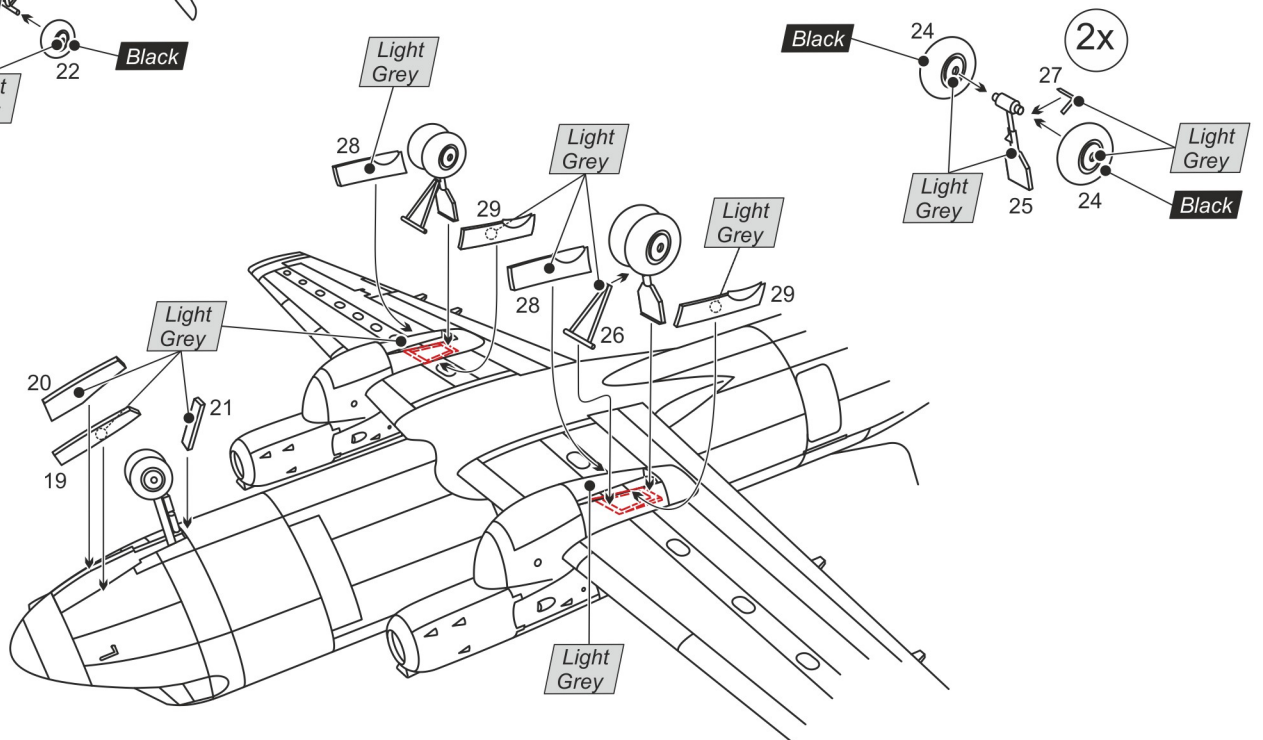

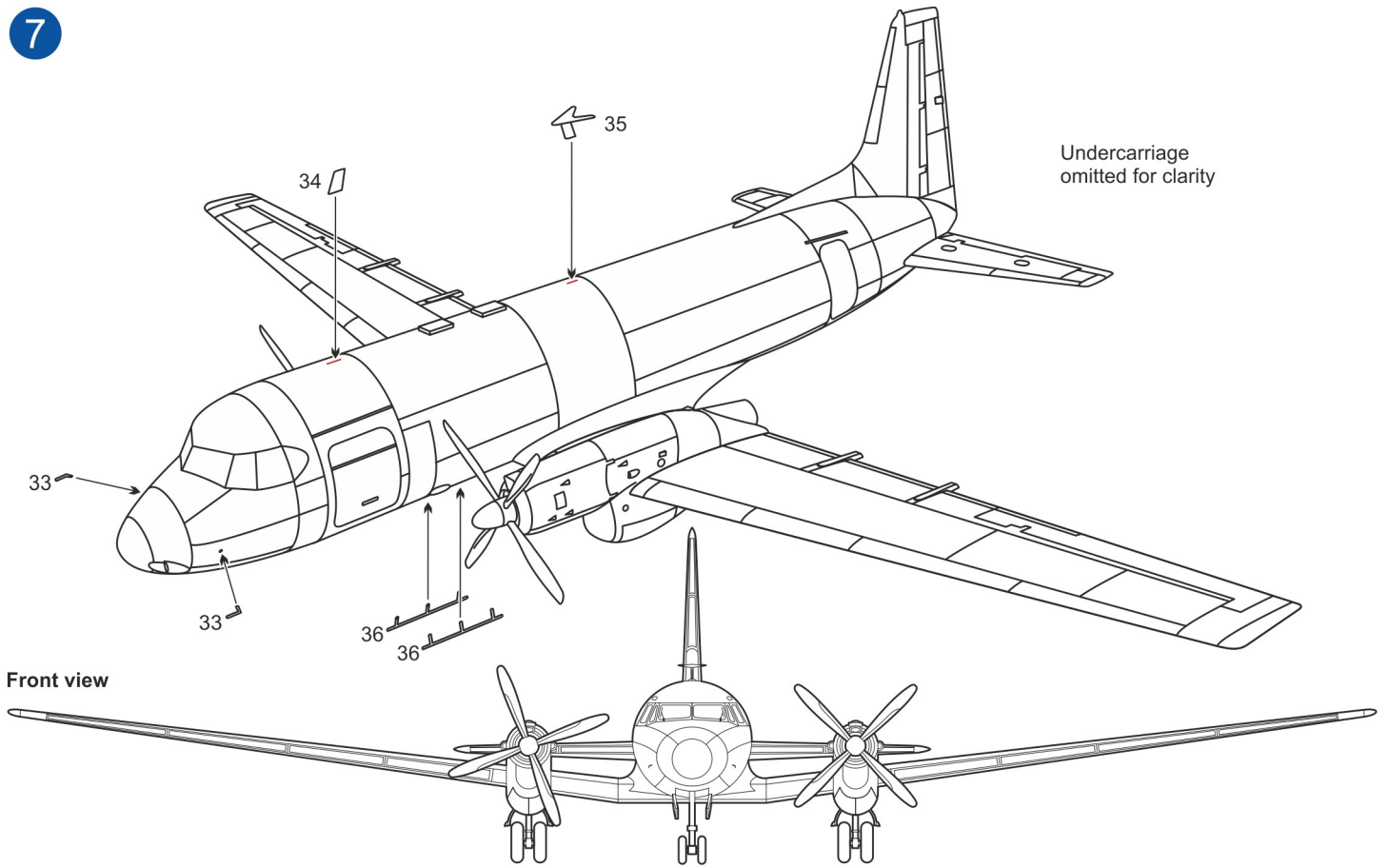

A Avro 748/Hawker Siddeley HS.748, Dan Air Services Ltd. (Dan-Air Skyways), flown between various regional and European airports, U.K., 1972-73

Avro 748:

- G-ARAY c/n 1535 (Srs.1 Model 200), entered service 05/1971 (ex-Maersk Air)
 - G-ARMW c/n 1537 (Srs.1 Model 101), entered service 04/1972 (ex-Skyways Coach-Air Ltd.)
 - G-ARMX c/n 1538 (Srs.1 Model 101), entered service 04/1972 (ex-Skyways Coach-Air Ltd.)
 - G-ARRW c/n 1549 (Srs.1 Model 106), entered service 04/1972 (ex-Skyways Coach-Air Ltd.)
- HS.748:**
- G-ASPL c/n 1560 (Srs.2 Model 108), entered service 04/1972 (ex-Skyways Coach-Air Ltd.)
 - G-AZSU c/n 1612 (Srs.2 Model 232), entered service 04/1972 (ex-BOAC)

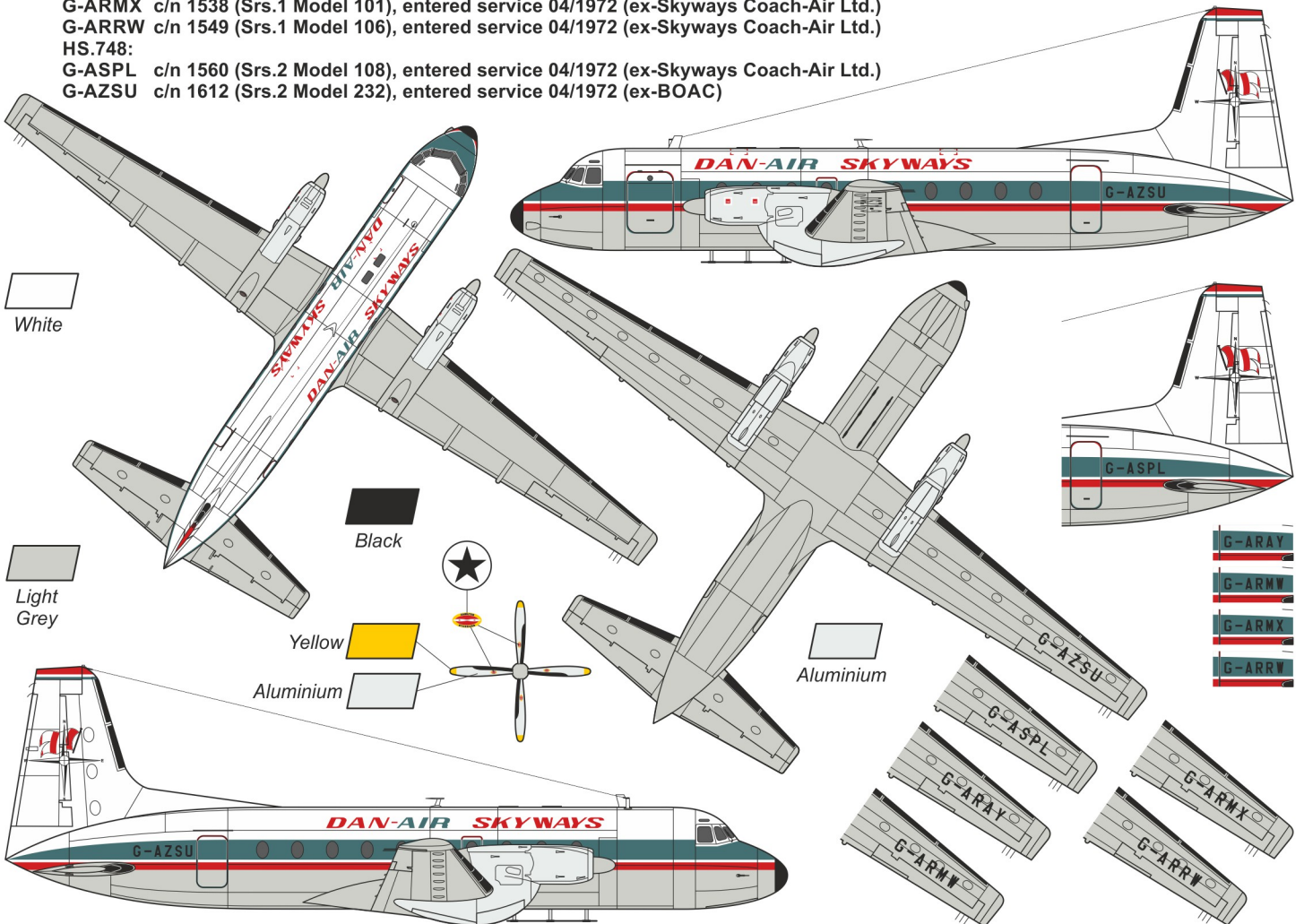

B Hawker Siddeley HS.748, Chieftain Airways PLC, flown between Scotland and European airports, Scotland, U.K., 1987
 G-GLAS c/n 1756 (Srs.2A Model 334), entered service 1987 (ex-Trinidad and Tobago Air Services Ltd.)
 G-EDIN c/n 1757 (Srs.2A Model 334), entered service 1987 (ex-Trinidad and Tobago Air Services Ltd.)

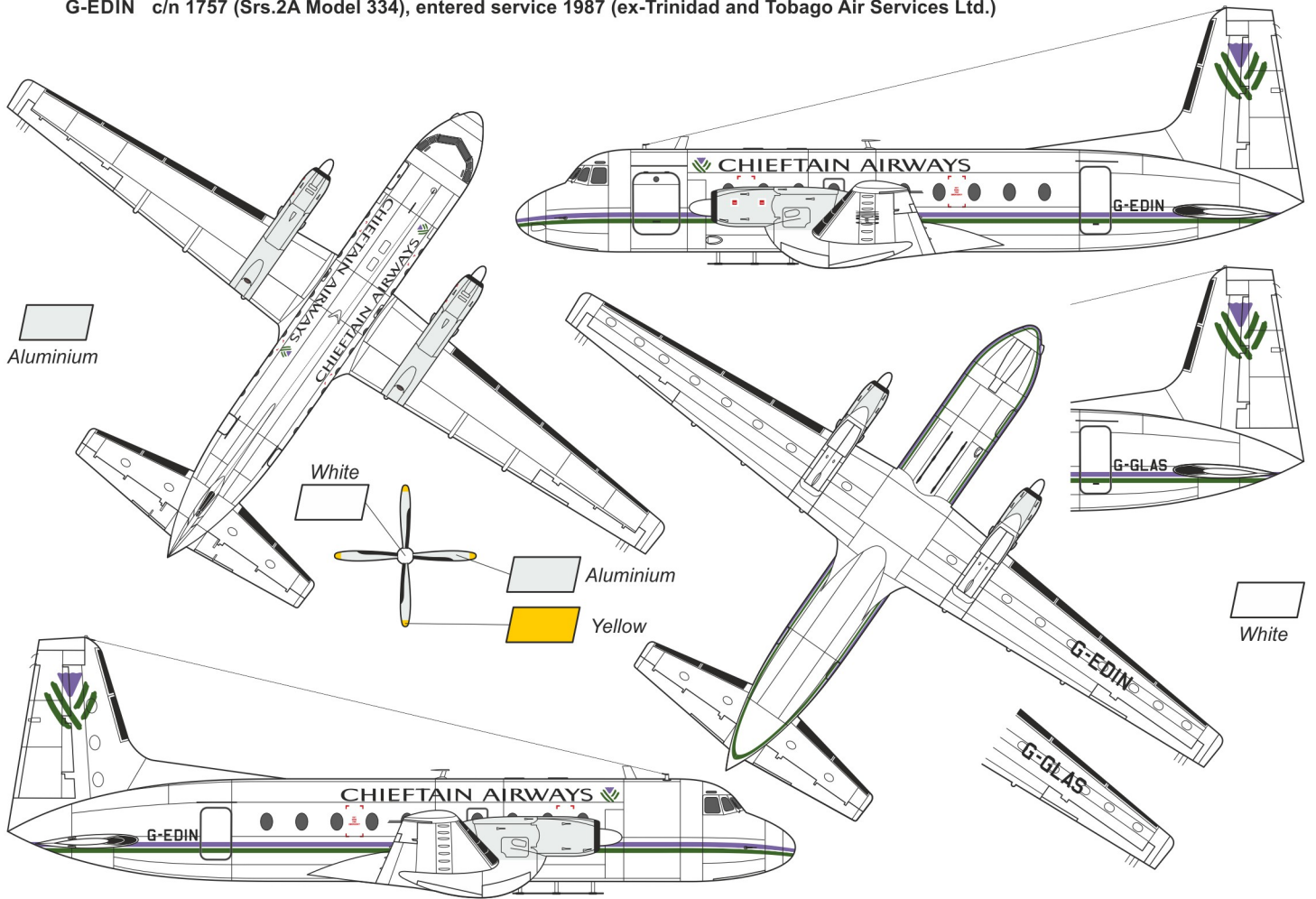

C Hawker Siddeley HS.748 (Srs.2 Model 215), YV-05C (c/n 1578), Línea Aeropostal Venezolana S.A. (LAV), Caracas - Simón Bolívar International Airport (Aeropuerto Internacional de Maiquetía "Simón Bolívar"), Venezuela, 1980-82

