

DE HAVILLAND MOSQUITO FB.VI

COMMONWEALTH SERVICE



MKM144125
1/144 scale

parts not
to be used

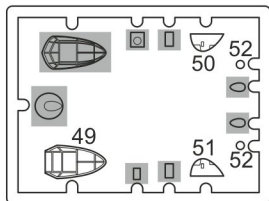

clear parts

MARK I Ltd.
PO Box 10
CZ-100 31 Prague 10
Czech Republic
mark1@cmail.cz
www.4pluspublications.com

plastic parts

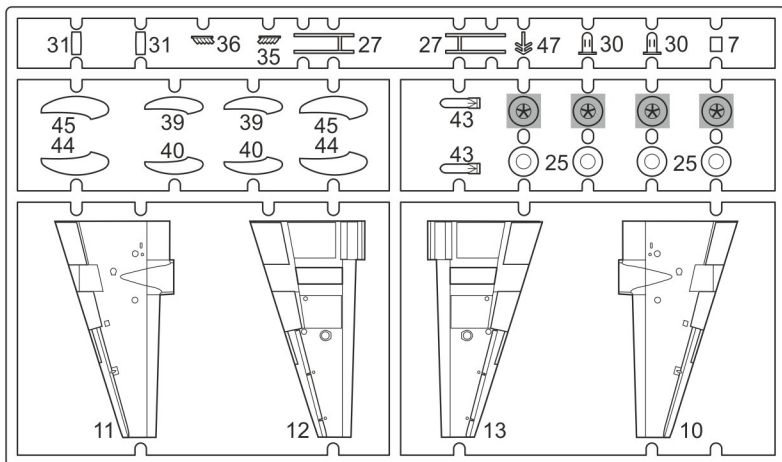
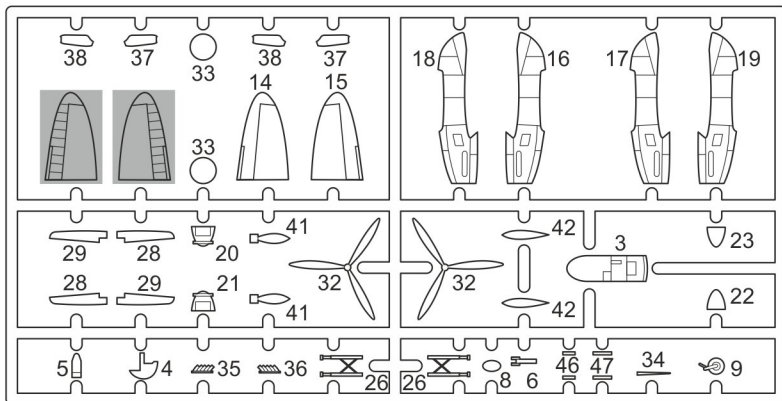
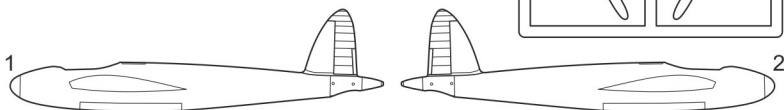
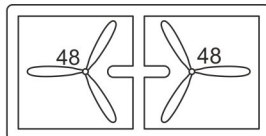

2x Repeat this operation

Glue

Decal

Drill

Detach/cut

Optional

1

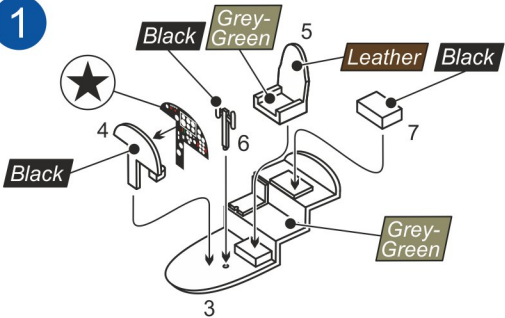

2

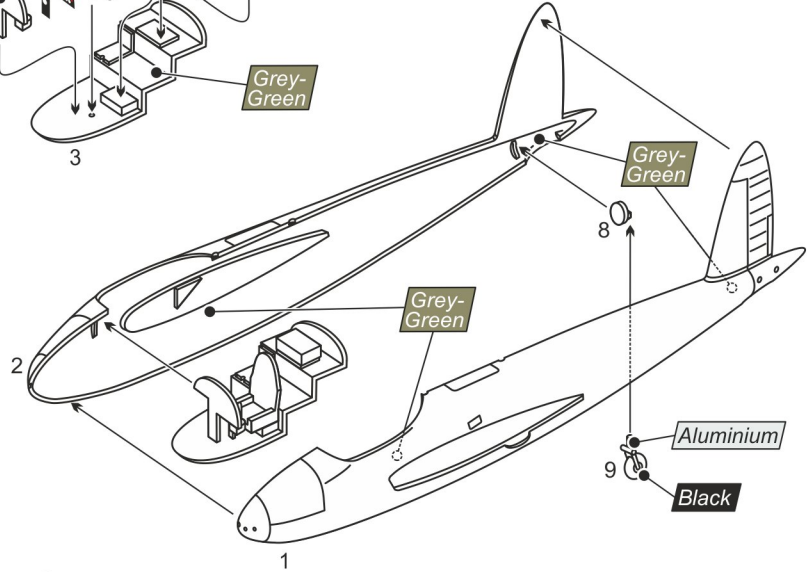

3

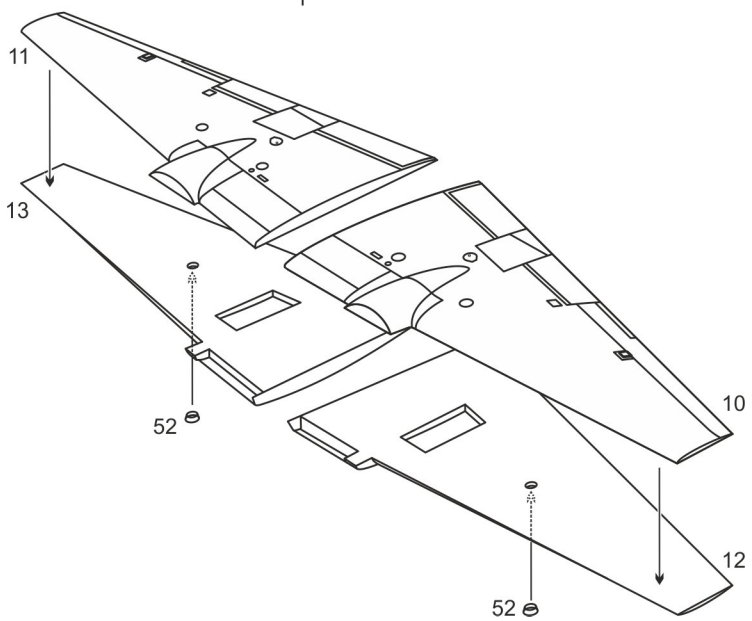

4

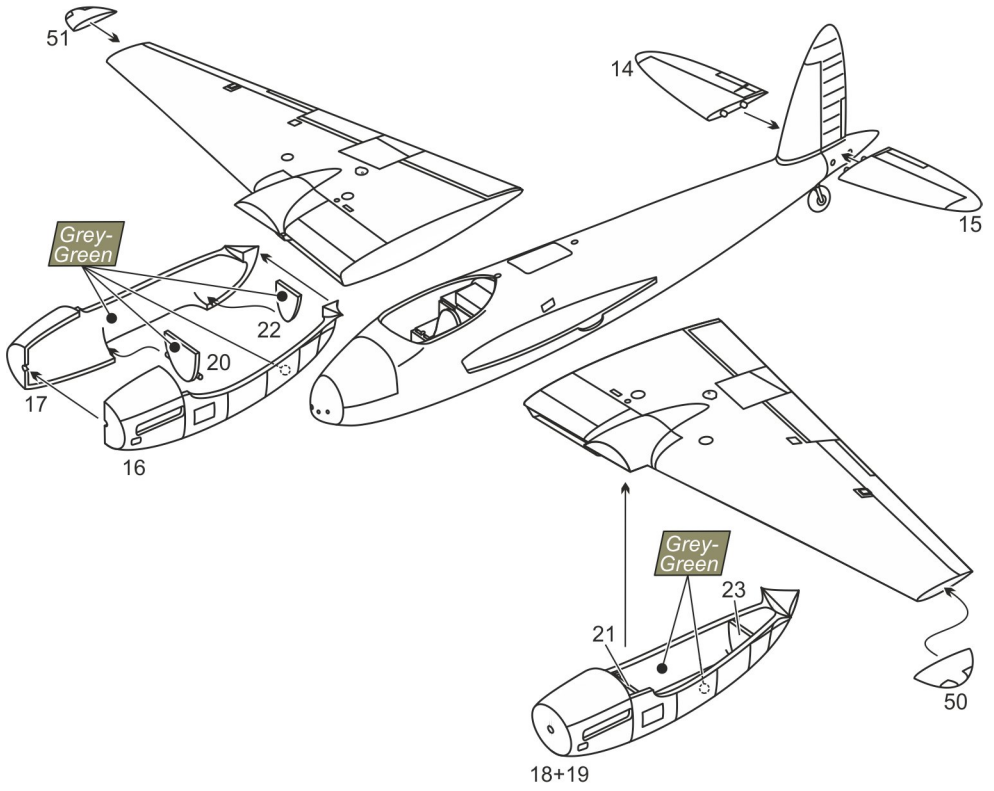

5

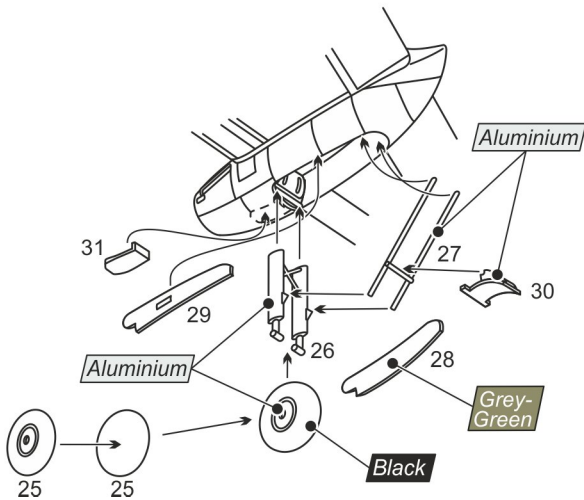

6

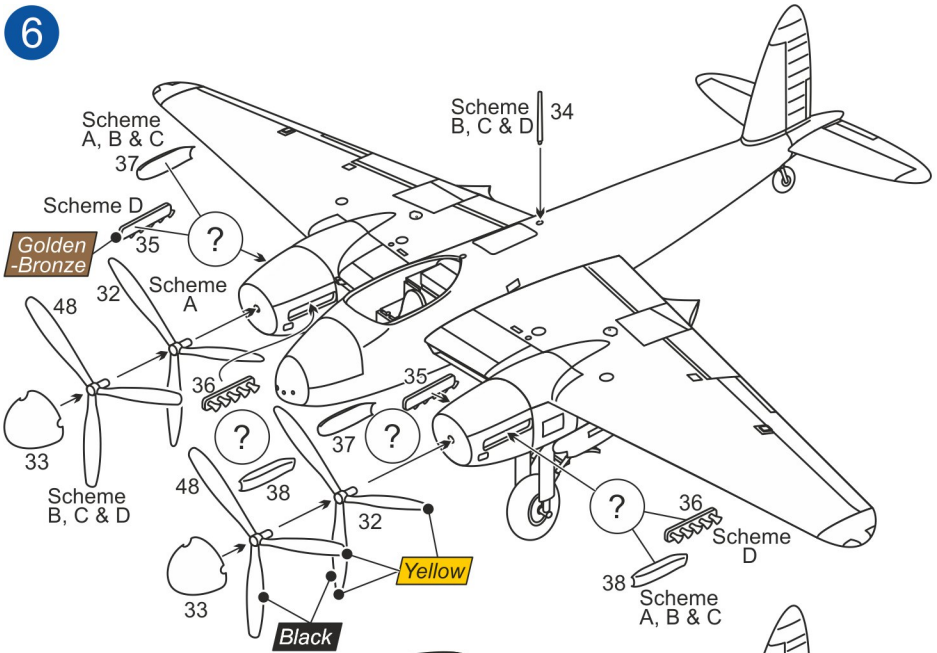

7

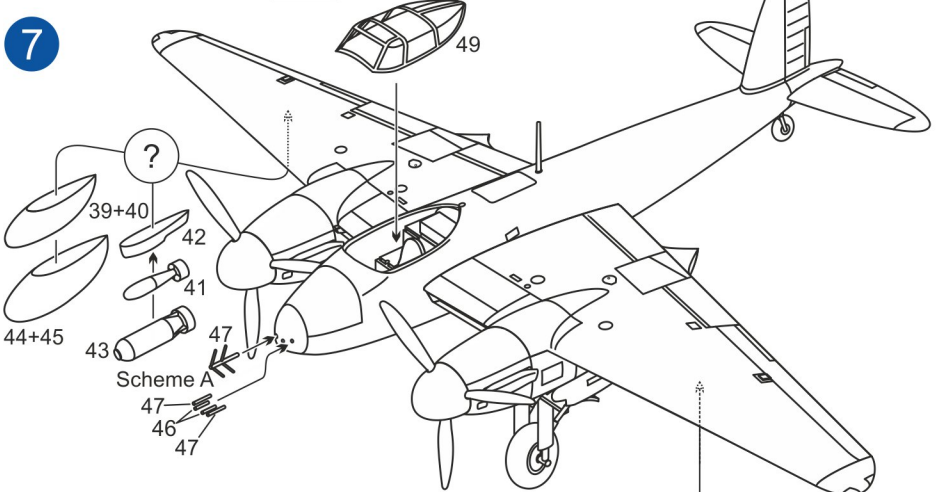

FB.VI bomb pylon/drop tank location

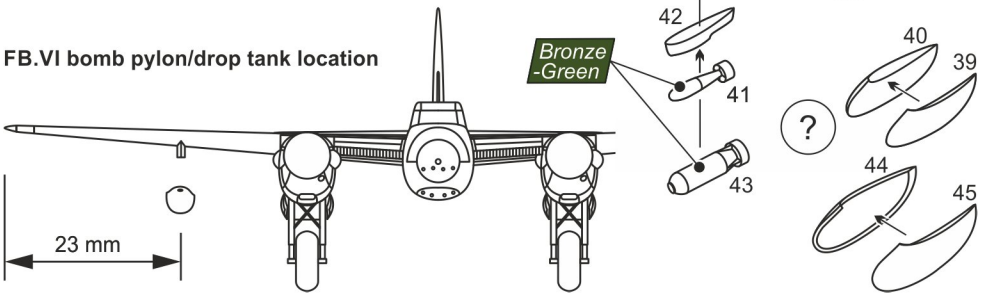



de Havilland DH.98 Mosquito FB Mk.VI (Srs.II), NZ2328 (ex-TE758), Black YC-C, No.75 Sq., Royal New Zealand Air Force, RNZAF Base Ohakea, North Island, New Zealand, 1950-52

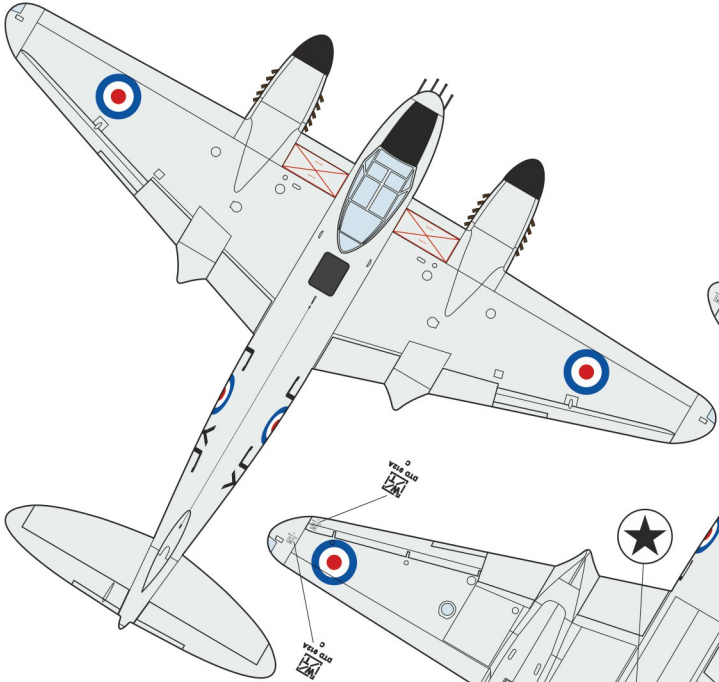
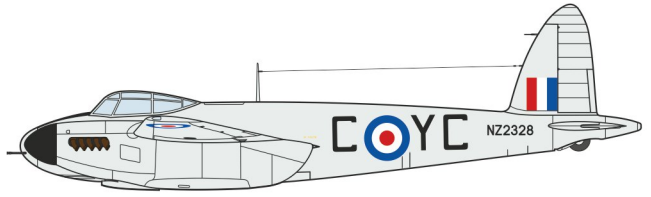
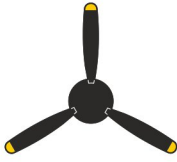

 Aluminium

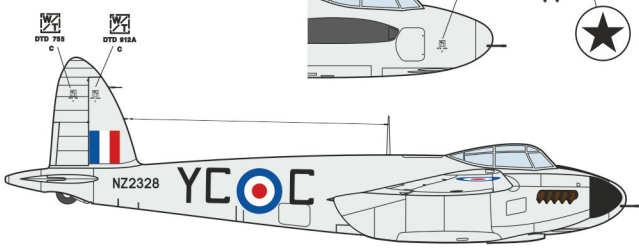
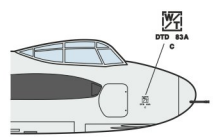
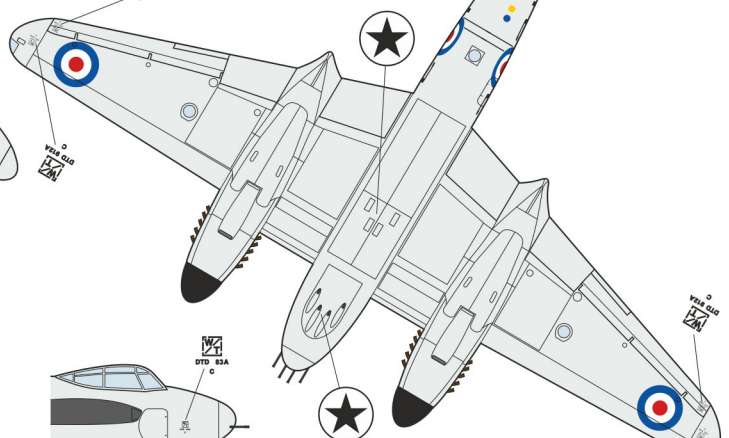
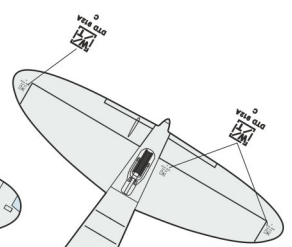

 DTD 758
C

 DTD 858A
C

 NZ
DTD 83A
C

 VERA 010
NZ

 VERA 010
NZ