

CURTISS P-36 HAWK

LATE HAWKS



MKM144126
1/144 scale

parts not
to be used

plastic parts

2x

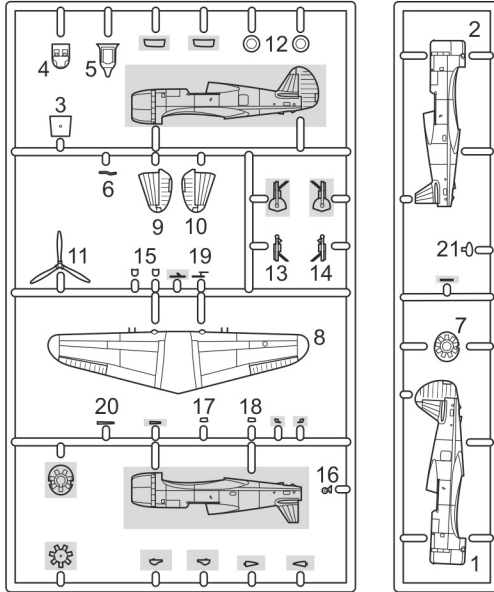

MARK I Ltd.
PO Box 10
Prague 10 - Strašnice
CZ-100 31
Czech Republic
mark1@cmail.cz
www.4pluspublications.com

clear parts
clear parts

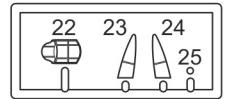

2x

2x Repeat this
operation

Glue

Don't
glue

Decal

Detach/
cut

? Optional

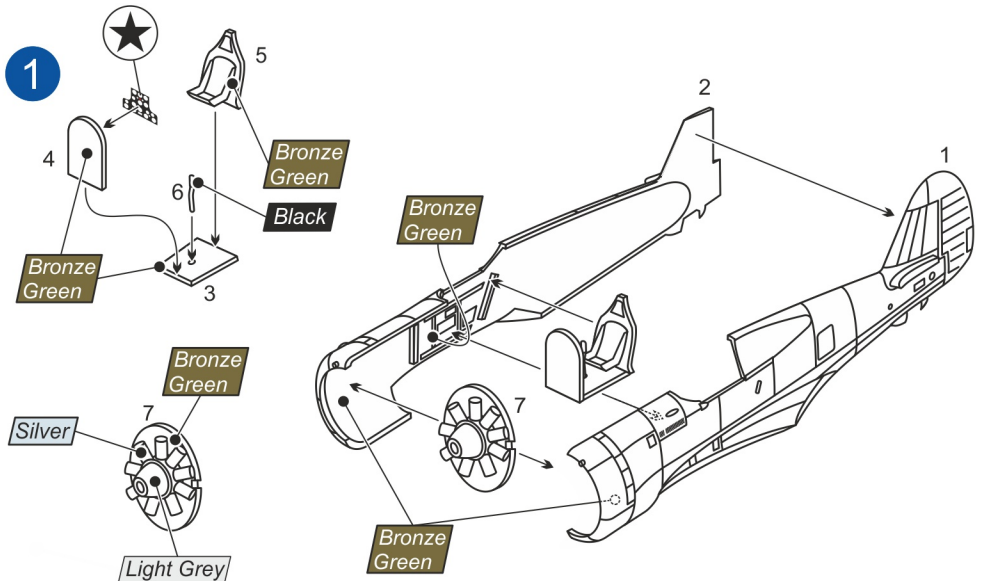

2

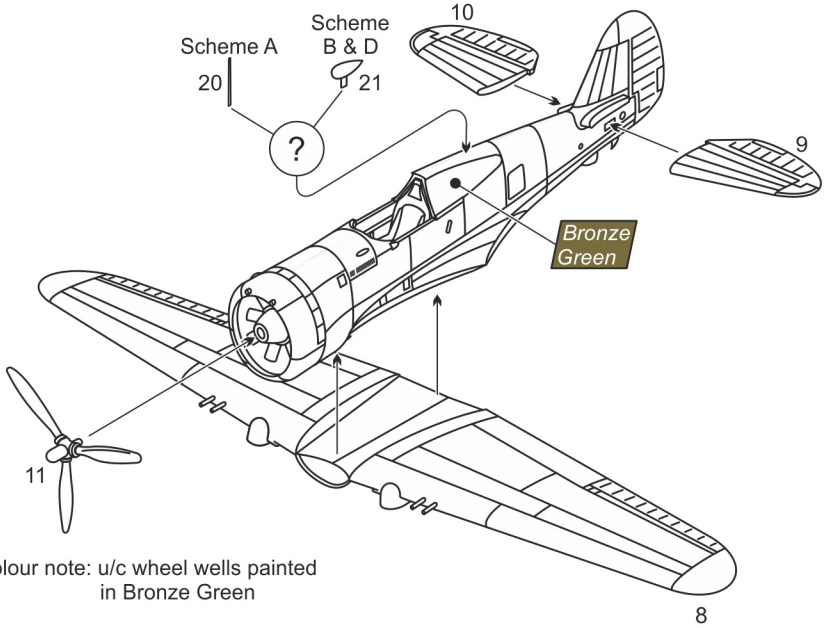

3

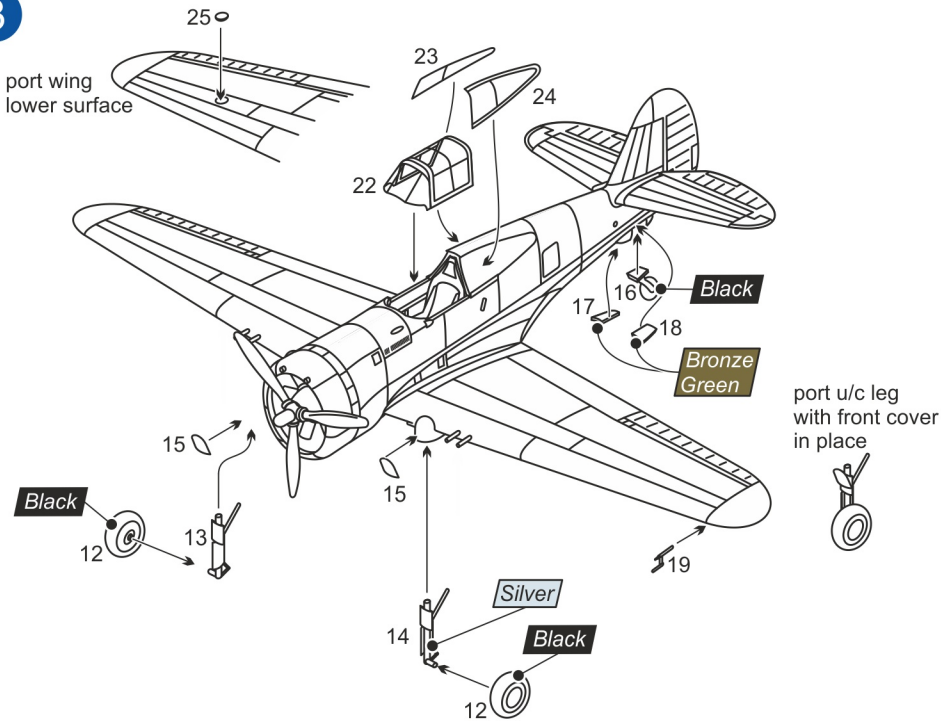

A Curtiss H-75A-4, CUc-504, (ex-French H-751 No.24/ex-Luftwaffe DS+NQ), 1/LeLv 12 (Fighter Sq.), Finnish Air Force (Ilmavoimat), Joroinen airfield, Finland, summer 1941

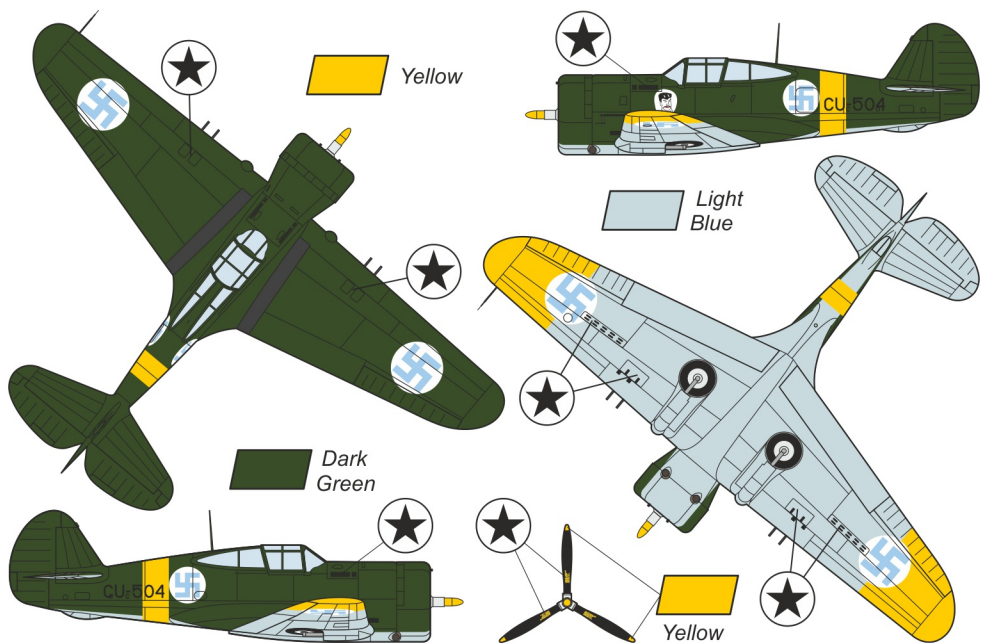

B Curtiss H-75A-8, No. 465, 'Little Norway' Air Force Training Camp, Norwegian Army Air Service (Hærens flyvåpen), Toronto Island Airport, Ontario, Canada, 1942-43

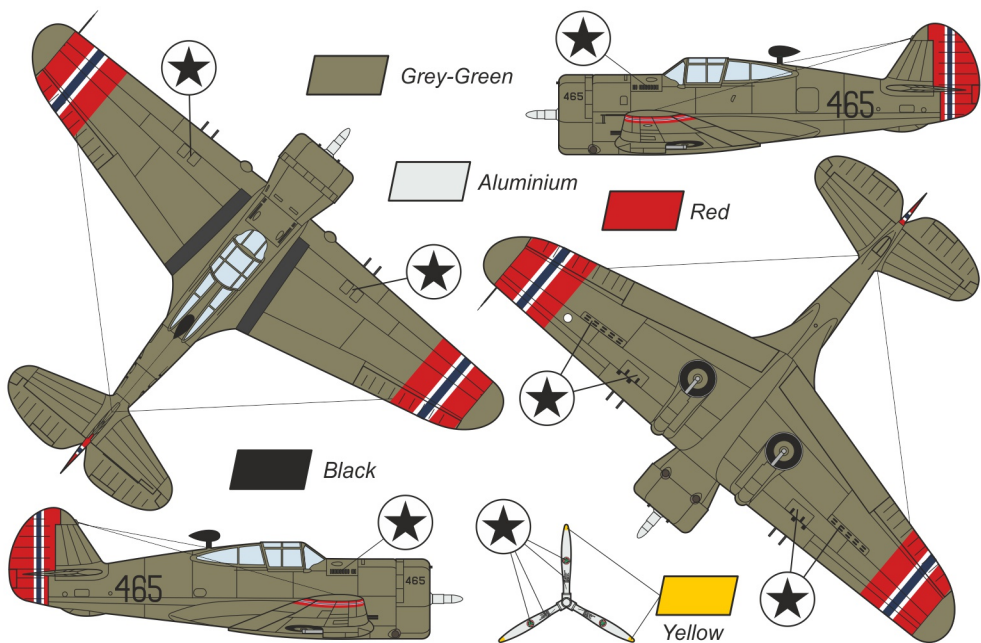

C Curtiss Mohawk Mk.IV, BS734, White 14, Air Transport Auxiliary Flight, Royal Air Force, Wroughton airfield, Wiltshire, U.K., 1941

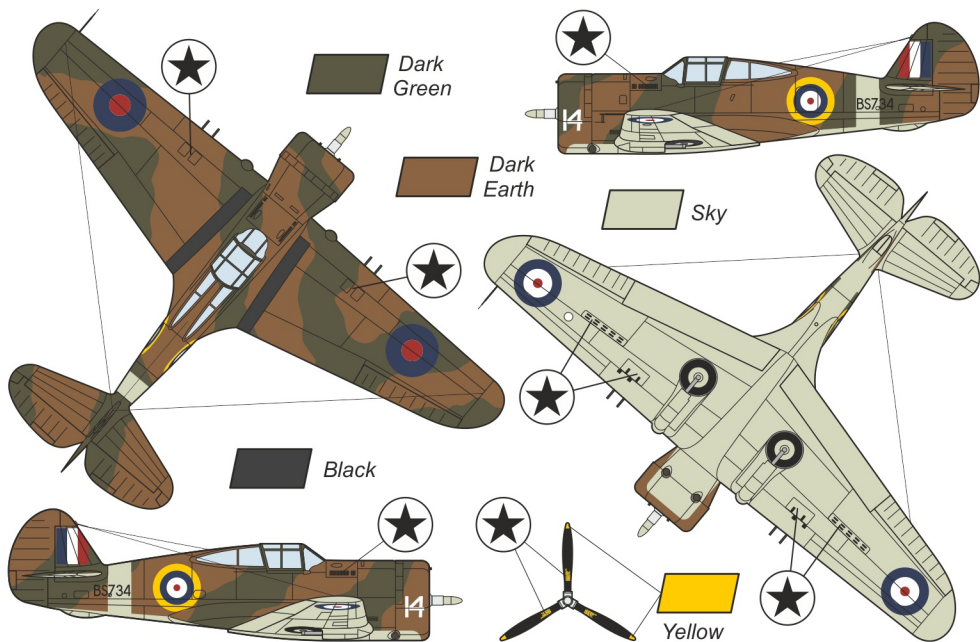

D Curtiss P-36G (ex-Norwegian H-75A-8), s/n 42-108995, Yellow 2108995, USAAF, Patterson Field, Ohio, U.S.A., early 1943

